



**ECOTECH**

environmental monitoring

# Serinus 51

## SO<sub>2</sub>/H<sub>2</sub>S Analyzer

**User Manual**  
**Version: 1.0**  
**July 2011**

Tel: (+61) 1300 364 946. Fax: (+61) 1300 668 763.  
E-mail: [ecotech@ecotech.com.au](mailto:ecotech@ecotech.com.au)  
Spare Parts [parts@ecotech.com.au](mailto:parts@ecotech.com.au)  
Address: **Australia - Head Office**  
*1492 Ferntree Gully rd Knoxfield Victoria, 3180, Australia*



# Manufacturers statement

Thank you for selecting the Ecotech Serinus 51 Sulfur Dioxide Analyzer.

The Serinus series is the next generation of Ecotech designed and manufactured gas analyzer, the Serinus 51 will perform Sulfur Dioxide measurements over a range of 0-2ppm with an LDL of 0.5 ppb.

This User Manual provides a complete product description including operating instructions, calibration, and maintenance requirements for the Serinus 51.

Reference should also be made to the relevant local standards, which should be used in conjunction with this manual. Some relevant standards are listed in the References section of this manual.

If, after reading this manual you have any questions or you are still unsure or unclear on any part of the Serinus 51 then please do not hesitate to contact Ecotech or your local Ecotech distributor.

Ecotech also welcomes any improvements that you feel would make this a more useable and helpful product then please send your suggestions to us here at Ecotech.



Please help the environment and recycle the pages of this manual when finished using it.

## Notice

The information contained in this manual is subject to change without notice. Ecotech reserves the right to make changes to equipment construction, design, specifications and /or procedures without notice.

**Copyright © 2011. All rights reserved. Reproduction of this manual, in any form, is prohibited without the written consent of Ecotech Pty Ltd.**



## WARNING

Hazardous voltages exist within the analyzer. The analyzer lid should be closed and quarter turn lid fasteners locked when the analyzer is left unattended or turned on. Ensure the power cord, plugs and sockets are maintained in a safe working condition and lid is closed and screw is fastened in place.

### Safety requirements

- To reduce the risk of personal injury caused by electrical shock, follow all safety notices and warnings in this documentation.
- If the equipment is used for purposes not specified by Ecotech, the protection provided by this equipment may be impaired.
- Replacement of any part should only be carried out by qualified personnel, using only parts specified by Ecotech as these parts meet stringent Ecotech quality assurance standards. Always disconnect power source before removing or replacing any components.

## Factory service/warranty

This product has been manufactured in an ISO 9001/ISO 14000 facility with care and attention to quality.

The product is subject to a 12-month warranty on parts and labor from date of shipment (the warranty period). The warranty period commences when the product is shipped from the factory. Lamps, fuses, batteries and consumable items are not covered by this warranty.

Each analyzer is subjected to a vigorous testing procedure prior to dispatch and will be accompanied with a parameter list and a multipoint calibration check thereby enabling the analyzer to be installed and ready for use without any further testing.

To ensure that we process your factory repairs and returned goods efficiently and expeditiously, we need your help. Before you ship any equipment to our factory, please call your local Ecotech service response centre (or distributor) to obtain a return authorization number.

When you contact Ecotech please provide the following information:

1. your name, telephone number and Facsimile number
2. Your company name
3. The model number or a description of each item
4. The serial number of each item, if applicable
5. A description of the problem or the reason you are returning the equipment (e.g. sales return, warranty return, calibration, etc)

If you are required to return the equipment an accompanying document with:

1. Your name, number and Facsimile number
2. Your company name with return shipment
3. The model number or a description of each item
4. The serial number of each item, if applicable

A description of the problem/reason you are returning the equipment

## **CE Mark Declaration of Conformity**

This declaration applies to the Serinus 51 SO<sub>2</sub> analyzers as manufactured by Ecotech Pty. Ltd. of 1492 Ferntree Gully Rd, Knoxfield, VIC, 3180, Australia, and which may be sold in the following configurations:

**To which this declaration relates is in conformity with the following European Union Directives:**

**Council Directive of 15 December 2004 on the approximation of the laws of Member States relating to electromagnetic compatibility (2004/108/EC)**

The following standard was applied:

**EN 61326-1:2006                      Electrical Equipment for measurement, control and laboratory use – EMC Requirements – Part 1: General requirements.**

- Immunity Requirements EN61326-1
  - IEC-61000-4-2    Electrostatic discharge immunity
  - IEC-61000-4-3    Radiated RF immunity
  - IEC-61000-4-4    Electrical fast transient burst immunity
  - IEC-61000-4-5    Surge immunity
  - IEC-61000-4-6    Conducted RF Immunity
  - IEC-61000-4-11   Voltage dips and interruption immunity
  
- Electromagnetic compatibility EN61326-1
  - CISPR-11            Radiated RF emission measurements
  - CISPR-11            Mains Terminal RF emission measurements
  - IEC-61000-3-3    Mains Terminal voltage fluctuation measurements
  - IEC-61000-3-2    Power Frequency harmonic measurements

**Council Directive of 12 December 2006 on the harmonization of the laws of Member States relating to electrical equipment designed for use within certain voltage limits (2006/95/EC)**

The following standard was applied:

**EN 61010-1:2001                      Safety requirements for electrical equipment, for measurement control and laboratory use – Part 1: General requirements**

- For protection against:
  - Electric shock or burn
  - Mechanical HAZARDS
  - Excessive temperature
  - Spread of fire from the equipment
  - Effects of radiation, including laser sources and sonic and ultrasonic pressure

# Claims for Damaged Shipments and Shipping Discrepancies

## **Damaged shipments**

1. Inspect all instruments thoroughly on receipt. Check materials in the container(s) against the enclosed packing list. If the contents are damaged and/or the instrument fails to operate properly, notify the carrier and Ecotech immediately.
2. The following documents are necessary to support claims:
  - a. Original freight bill and bill lading
  - b. Original invoice or photocopy of original invoice
  - c. Copy of packing list
  - d. Photographs of damaged equipment and container
  - e. Contact you freight forwarder for insurance claims







You may want to keep a copy of these documents for your records also.

Refer to the instrument name, model number, serial number, sales order number, and your purchase order number on all claims. Upon receipt of a claim, we will advise you of the disposition of your equipment for repair or replacement.

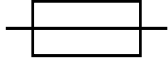
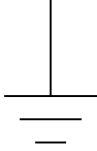
## **Shipping Discrepancies**

Check all containers against the packing list immediately on receipt. If a shortage or other discrepancy is found, notify the carrier and Ecotech immediately. We will not be responsible for shortages against the packing list unless they are reported promptly (within 7 days).

## Internationally recognized symbols used on Ecotech Equipment

	Electrical fuse	IEC 60417-5016
	Earth (ground) terminal	IEC 60417-5017
	Protective conductor terminal	IEC 60417-5017
	Equipotentiality	IEC 60417-5021
	Alternating current	IEC 60417-5032
	Caution, hot surface	IEC 60417-5041
	Caution, risk of danger. Refer to accompanying documents	ISO 7000-0434
	Caution, risk of electric shock	ISO 3864-5036



# Manual Revision History

**Ecotech Manual ID:** MAN 0080  
**Manual PN:** M010040  
**Current Revision:** 1.0  
**Date released:** July 2011  
**Description:** User Manual for the Serinus 51 SO<sub>2</sub>/H<sub>2</sub>S analyzer

This manual is the full user manual for the Serinus 51 SO<sub>2</sub>/H<sub>2</sub>S analyzer. This manual contains all relevant information on theory, specifications, installation, operation, maintenance, calibration, communication and troubleshooting. Any information that cannot be found within this manual can be found by contacting Ecotech at:

Email: Help	<a href="mailto:help@ecotech.com.au">help@ecotech.com.au</a>
Service	<a href="mailto:service@ecotech.com.au">service@ecotech.com.au</a>
Parts	<a href="mailto:parts@ecotech.com.au">parts@ecotech.com.au</a>
Phone:	+61 1300 364 946
Fax:	+61 1300 668 763
Address:	Ecotech Pty Ltd 1492 Ferntree Gully Rd Knoxfield Victoria Australia 3180
Website	<a href="http://www.ecotech.com">www.ecotech.com</a>

<b>Edition</b>	<b>Date</b>	<b>Summary</b>	<b>Pages</b>
1.0	July 2011	Initial release	all

# Table of Contents

<b><u>1</u></b>	<b><u>INTRODUCTION</u></b>	<b><u>1</u></b>
1.1	DESCRIPTION	1
1.2	SPECIFICATIONS	1
1.2.1	MEASUREMENT	1
1.2.2	PRECISION/ACCURACY	1
1.2.3	CALIBRATION	1
1.2.4	POWER	2
1.2.5	OPERATING CONDITIONS	2
1.2.6	COMMUNICATIONS	2
1.2.7	PHYSICAL DIMENSIONS	3
1.3	NOMENCLATURE	3
1.4	BACKGROUND/ THEORY	4
1.4.1	MEASUREMENT THEORY	4
1.4.2	KALMAN FILTER THEORY	5
1.5	INSTRUMENT DESCRIPTION	5
1.5.1	PARTICULATE FILTER	6
1.5.2	HYDROCARBON KICKER	6
1.5.3	ZERO AIR SCRUBBER	6
1.5.4	REACTION CELL	7
1.5.5	MAIN CONTROLLER PCB	7
1.5.6	REFERENCE DETECTOR PREAMPLIFIER	7
1.5.7	PMT HIGH VOLTAGE SUPPLY AND PREAMPLIFICATION	7
1.5.8	LAMP DRIVER PCB	8
1.5.9	PRESSURE PCB	8
1.5.10	POWER SUPPLY	8
1.5.11	COMMUNICATIONS	9
<b><u>2</u></b>	<b><u>INSTALLATION</u></b>	<b><u>10</u></b>
2.1	INITIAL CHECK	10
2.2	MOUNTING/SITING	11
2.3	INSTRUMENT SETUP	11
2.3.1	PNEUMATIC CONNECTIONS	11
2.3.2	POWER CONNECTIONS	12
2.3.3	COMMUNICATIONS CONNECTIONS	13
2.3.4	ANALYZER SET UP	13
2.4	U.S. EPA REFERENCE SET UP	14
2.5	TRANSPORTING/STORAGE	14
<b><u>3</u></b>	<b><u>OPERATION</u></b>	<b><u>15</u></b>
3.1	WARMUP	15
3.2	GENERAL OPERATIONAL INFORMATION	15
3.3	MAIN SCREEN	16
3.4	SAMPLING	17
3.5	MENUS AND SCREENS	18
3.5.1	QUICK MENU	18

3.5.2	ANALYZER STATE.....	20
3.5.3	GENERAL SETTINGS.....	23
3.5.4	MEASUREMENT SETTINGS .....	23
3.5.5	CALIBRATION MENU .....	24
3.5.6	SERVICE.....	26
3.5.7	COMMUNICATIONS .....	31
<b>4</b>	<b><u>CALIBRATION .....</u></b>	<b><u>35</u></b>
4.1	ZERO CALIBRATION.....	35
4.2	SPAN CALIBRATION .....	35
4.3	MULTIPOINT CALIBRATION .....	36
4.4	PRESSURE CALIBRATION .....	39
4.5	PRECISION CHECK.....	40
<b>5</b>	<b><u>COMMUNICATIONS .....</u></b>	<b><u>42</u></b>
5.1	RS232 COMMUNICATION.....	42
5.2	USB COMMUNICATION.....	42
5.3	TCP/IP NETWORK COMMUNICATION.....	42
5.4	DIGITAL/ANALOG COMMUNICATION .....	46
5.5	SERINUS DOWNLOADER PROGRAM .....	48
5.5.1	SETTINGS .....	48
5.5.2	DATA .....	50
5.5.3	REMOTE SCREEN.....	51
5.5.4	REMOTE TERMINAL .....	52
<b>6</b>	<b><u>SERVICE .....</u></b>	<b><u>53</u></b>
6.1	PNEUMATIC DIAGRAM .....	53
6.2	MAINTENANCE TOOLS .....	53
6.3	MAINTENANCE SCHEDULE.....	54
6.4	MAINTENANCE PROCEDURES .....	55
6.4.1	PARTICULATE FILTER REPLACEMENT.....	55
6.4.2	CLEAN FAN FILTER .....	55
6.4.3	DFU REPLACEMENT .....	56
6.4.4	QUICK LEAK TEST.....	56
6.4.5	ADVANCED LEAK CHECK.....	58
6.4.6	REPLACE ZERO AIR SCRUBBER.....	58
6.4.7	REPLACE PMT DESICCANT PACK .....	59
6.4.8	REPLACE DFU FILTER .....	60
6.4.9	CHECK UV LAMP ALIGNMENT.....	60
6.4.10	PRESSURE SENSOR CHECK .....	61
6.5	PARTS LIST.....	63
6.6	UPDATING FIRMWARE .....	64
<b>7</b>	<b><u>TROUBLESHOOTING .....</u></b>	<b><u>65</u></b>
7.1	ZERO FLOW .....	66
7.2	ELECTRONIC ZERO ADJUST.....	67
7.3	SO <sub>2</sub> REACTION CELL TEMPERATURE FAILURE.....	67

<b>8</b>	<b><u>OPTIONAL EXTRAS.....</u></b>	<b><u>69</u></b>
<b>8.1</b>	<b>DUAL SAMPLE FILTER.....</b>	<b>69</b>
<b>8.2</b>	<b>RACK MOUNT KIT.....</b>	<b>69</b>
<b>8.3</b>	<b>INTERNAL PUMP.....</b>	<b>71</b>
8.3.1	PNEUMATIC DIAGRAM (INTERNAL PUMP).....	71
8.3.2	ADDITIONAL COMPONENTS.....	71
8.3.3	REMOVED COMPONENTS.....	71
8.3.4	MENUS.....	71
8.3.5	FLOW CALIBRATION.....	71
8.3.6	PRESSURE CALIBRATION.....	71
<b>8.4</b>	<b>HIGH PRESSURE ZERO/SPAN VALVE.....</b>	<b>71</b>
8.4.1	SINGLE PRESSURIZED CALIBRATION OPTION.....	71
8.4.2	DUAL PRESSURIZED CALIBRATION OPTION.....	72
	<b><u>APPENDIX A ADVANCED PROTOCOL PARAMETER LIST.....</u></b>	<b><u>75</u></b>
	<b><u>APPENDIX B – EC9800 PROTOCOL.....</u></b>	<b><u>82</u></b>
	<b><u>APPENDIX C – BAVARIAN PROTOCOL.....</u></b>	<b><u>84</u></b>

## List of Figures

Figure 1 Simple pneumatic diagram.....	4
Figure 2 Optical measurement theory.....	5
Figure 3 Major Components.....	6
Figure 4 Opening the lid.....	10
Figure 5 Instrument Back panel.....	11
Figure 6. Switching battery off.....	14
Figure 7 Serinus front panel.....	15
Figure 8 Excel graph of Multipoint Calibration.....	38
Figure 9 Pressure Calibration.....	39
Figure 10 Pressure menu.....	40
Figure 11 Communication ports.....	42
Figure 11 Device Installer pop up window.....	43
Figure 12 Device Installer XPort-03.....	43
Figure 13 Device Installer - Telnet Configuration.....	44
Figure 14 Serinus 25 pin microprocessor board (with default jumpers highlighted).....	46
Figure 15 External 25pin I/O individual pin descriptions.....	47
Figure 16 Serinus downloader - settings tab.....	49
Figure 17 Serinus Downloader – Data tab.....	50
Figure 18 Serinus Downloader – Remote Screen tab.....	51
Figure 19 Serinus downloader - Remote Terminal tab.....	52
Figure 17 Pneumatic diagram.....	53
Figure 18 Removing plunger.....	55
Figure 19 Removing fan filter.....	55
Figure 20 Plugged sample and calibration ports.....	57
Figure 21 Zero scrubber removal.....	58
Figure 22 Position of desiccant packs.....	59
Figure 23 Collets of the UV lamp.....	61
Figure 24 Dual filter option installed.....	69
Figure 25 Installation of rack mount brackets.....	69
Figure 26 Installation of lid to rack mount brackets.....	70
Figure 27 Rack slide lock.....	70
Figure 28 Pneumatic diagram with internal pump.....	71
Figure 29 Single high pressure calibration option.....	72
Figure 30 Dual high pressure calibration option.....	73

## List of Tables

Table 1 Maintenance Schedule.....	54
Table 2 Parts List.....	63
Table 3 Troubleshoot list.....	65
Table 4 Zero flow Troubleshoot.....	66
Table 5 Internal pump additional components.....	71
Table 6 Internal pump removed components.....	71
Table 7 Advanced Protocol Parameter list.....	75

## List of Equations

Equation 1 Instrument accuracy.....	37
-------------------------------------	----

# 1 Introduction

---

## 1.1 Description

The Serinus 51 SO<sub>2</sub>/H<sub>2</sub>S analyzer uses UV fluorescent radiation technology to detect Sulfur Dioxide and Hydrogen Sulfide to a sensitivity of 0.5 ppb in the range of 0-2 ppm. The Serinus 51 measures SO<sub>2</sub>/H<sub>2</sub>S with the following instruments/techniques:

- SO<sub>2</sub> scrubber
- Thermal converter
- Hydrocarbon kicker
- UV lamp
- Fluorescence cell
- Optical bandpass filters
- Photomultiplier tube (PMT)

H<sub>2</sub>S is measured by first scrubbing the SO<sub>2</sub> out of the sample with an SO<sub>2</sub> scrubber, and then converting H<sub>2</sub>S into SO<sub>2</sub> with a thermal converter, The SO<sub>2</sub> concentration measured is performed directly with a bypass taking the sample around the SO<sub>2</sub> scrubber and thermal converter. All measurements are automatically corrected for gas temperature and pressure changes and referenced to 0°C, 20°C or 25°C at 1 atmosphere. This allows the Serinus 51 to sample in the most useful range of SO<sub>2</sub> and H<sub>2</sub>S ambient measurement (0-25 ppb SO<sub>2</sub> in air.). This manual will detail the operation, calibration, preventive maintenance, cautions and health warnings.

## 1.2 Specifications

### 1.2.1 Measurement

---

**Range:**

- 0-2 ppm auto ranging

**Lower detectable limit:**

- < 0.5 ppb or 0.2% of concentration reading, whichever is greater; with Kalman filter active.

### 1.2.2 Precision/Accuracy

---

**Precision:**

- 0.5 ppb

**Linearity:**

- ±1% of full scale (from best straight-line fit).

**Sample flow rate:**

- 0.725 slpm

### 1.2.3 Calibration

---

**Zero drift**

- Temperature dependant: 0.1 ppb per °C
- 24 hours: < 1.0 ppb
- 30 days: < 1.0ppb

**Span drift**

- Temperature dependant: 0.1% per °C
- 24 hours: 0.5% of reading
- 30 days: 0.5% of reading

---

**1.2.4 Power**

---

**Operating voltage:**

- 99 to 132 VAC, 198 to 264 VAC, 47 to 63 Hz

**Power Consumption:**

- 311VA max.( typical at start up)
- 129VA after warm up

**Fuse Rating:**

- 20x5mm, T 250V, 5A (slow blow).

---

**1.2.5 Operating conditions**

---

**Ambient Temperature Range:**

- 5°C to 40 °C (41 °F to 104 °F)

**Sample pressure dependence:**

- 5% change in pressure produces less than a 1% change in reading
- Maximum Altitude, 3000m above sea level

---

**1.2.6 Communications**

---

**Analog Output**

- Menu selectable current output of 0-20 mA, 2-20mA or 4-20 mA or
- Voltage output of 0 to 5 V, with menu selectable zero offset of 0%, 5%, or 10%.
- Range: 0 full scale from 0-0.05 ppm to 0-20 ppm with 0%, 5%, and 10% offset.
- Resolution: 0.5 ppb or 0.2% of analog output full scale, whichever is greater.

**Analog Input**

- Three analog voltage inputs (0-5VDC) CAT I rated.

**Digital Output**

- RS232 port #1: Normal digital communication or termination panel connection
- RS232 port #2: Multidrop port used for multiple analyzer connections on a single RS232
- USB port connection on rear panel
- 25 pin connector with discrete status and user control
- USB stick memory (front panel) for data logging, event logging and parameter storage
- 8 Digital Outputs, open collector 150mA each.
- 8 Digital Inputs, 0-5VDC, CAT I rated.

---

## 1.2.7 Physical dimensions

---

**Case dimensions:**

- Length: 620mm with no handle (24.4" inches)
- Width: 440mm (17.3" inches)
- Height: 178mm/4RU (7" inches)

**Weight:** 18.1kg

## 1.3 Nomenclature

**Span:** A gas sample of known composition and concentration used to calibrate/check the upper range of the instrument (Sulfur Dioxide).

**Zero:** Zero calibration uses zero air (SO<sub>2</sub> scrubbed ambient air) to calibrate/check the lower range of the instrument.

**Background:** External signals that can be confused with that of the signal being measured.

**Zero drift:** the change in instrument response to zero pollutant concentration over 12hr and 24hr periods of continuous unadjusted operation.

**Automatic zero:** The automatic zero performs a zero check at a specified time through a 24 hour cycle which adjusts the lower limit of the analyzers.

**Zero air:** Purified air in which the combined effect of the concentration of impurities is less than 1% of the relevant midrange of the analyzer instrument. Sufficient purified air can be obtained by passing dry ambient air through an activated charcoal filter and a particulate filter.

**External span source:** Span gas that is delivered via an external accredited cylinder (e.g. NATA/NIST).

**Sample Air:** Sample air is defined as the sample before it has entered the reaction cell, as distinguished from the exhaust air.

**Exhaust air:** Exhaust air is the sample air after it has passed through the reaction/measurement/detection cell and is moving towards being expelled from the analyzer.

**ID and OD:** Measurements of tubing, ID is the internal diameter of tubing, OD is the outer diameter.

## 1.4 Background/ Theory

### Sulfur Dioxide

Sulfur Dioxide is the product of the combustion of sulfur compounds and causes significant environmental pollution. The main source of SO<sub>2</sub> in the environment are from various industrial processes such as the burning of coal in power stations, the extraction of metals from ore and combustion of fuel within automobiles.

Sulfur dioxide is a noxious gas that can cause respiratory damage as well as impairing visibility when in high concentrations. Sulfur Dioxide also has the potential to form Acid rain (H<sub>2</sub>SO<sub>4</sub>) which causes health, environmental and infrastructural problems to human society.

### Hydrogen Sulfide

Hydrogen sulfide is created through industrial processes and released into the atmosphere. The main sources of anthropogenic Hydrogen sulfide (H<sub>2</sub>S) emissions are from petroleum refineries, paper mills, coke ovens (aluminum, steel, graphite, electrical, and construction industries) and to a smaller extent tanneries.

Hydrogen sulfide is toxic to many different parts of the human body, it effects the nervous system most acutely and also inhibits respiration. General harmful levels of Hydrogen sulfide (H<sub>2</sub>S) exposure are 5-10 ppm, levels above this begin with eye irritation and lead up to death.

#### 1.4.1 Measurement Theory

The measurement of sulfur dioxide is based on classical fluorescence spectroscopy principles. Sulfur dioxide (SO<sub>2</sub>) exhibits a strong ultraviolet (UV) absorption spectrum between 200 and 240nm, when SO<sub>2</sub> absorbs UV from this, emission of photons occurs (300-400nm). The amount of fluorescence emitted is directly proportional to the SO<sub>2</sub> concentration. The Serinus 51 follows these principles and measurement techniques:

- Sample air is passed through a hydrocarbon kicker a device which removes hydrocarbons from sample air

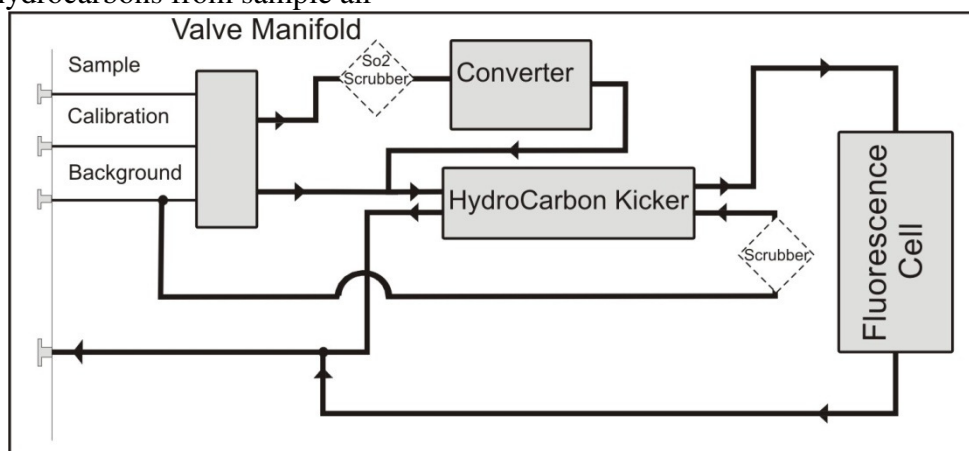
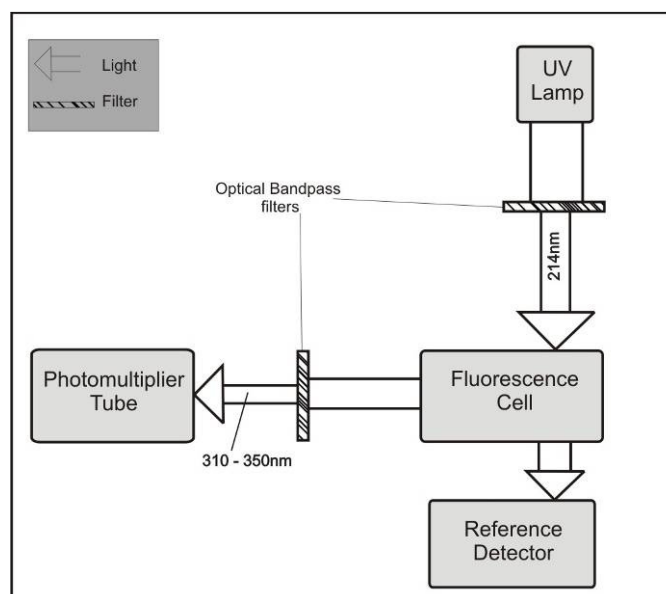

Figure 1 Simple pneumatic diagram

- A zinc discharge lamp and a UV bandpass filter is used to produce radiation at 214nm.

- The radiation (214nm) is focused into the fluorescence cell where it interacts with SO<sub>2</sub> molecules and emits photons uniformly in all directions.
- A portion of the fluorescence is collected and filtered.
- Wavelengths at 310-350nm pass through the filter where they reach the photomultiplier and record a signal.
- A reference detector monitors the emission from the zinc lamp and is used to correct for fluctuations in lamp intensity.



**Figure 2 Optical measurement theory**

- Air drawn from the Background Port is scrubbed via charcoal and then passed through a particulate filter. This air is then available for use by the Hydrocarbon Kicker and is also used to perform zero background adjustments.

## 1.4.2 Kalman filter theory

The Serinus analyzer series use the advanced digital Kalman filter. This filter provides the best possible compromise between response time and noise reduction for the type of signal and noise present in ambient air analyzers.

The Kalman filter enhances measurements by making the filter time base variable, depending on the change rate of the measured value. If the signal rate is changing rapidly, the instrument is allowed to respond quickly. When the signal is steady, a long integration time is used to reduce noise. The system continuously analyzes the signal and uses the appropriate filtering time.

## 1.5 Instrument description

The Sulfur Dioxide analyzer consists of five main assemblies:

- The pneumatics to transfer sample and exhaust gas

- The sensors for the measurement of SO<sub>2</sub> (optical cell) and other relevant parameters
- The control system which encompasses all circuit boards, is used to control all sensors and pneumatic components
- The power supply which supplies power for all the instrument processors
- The Communication module to access data

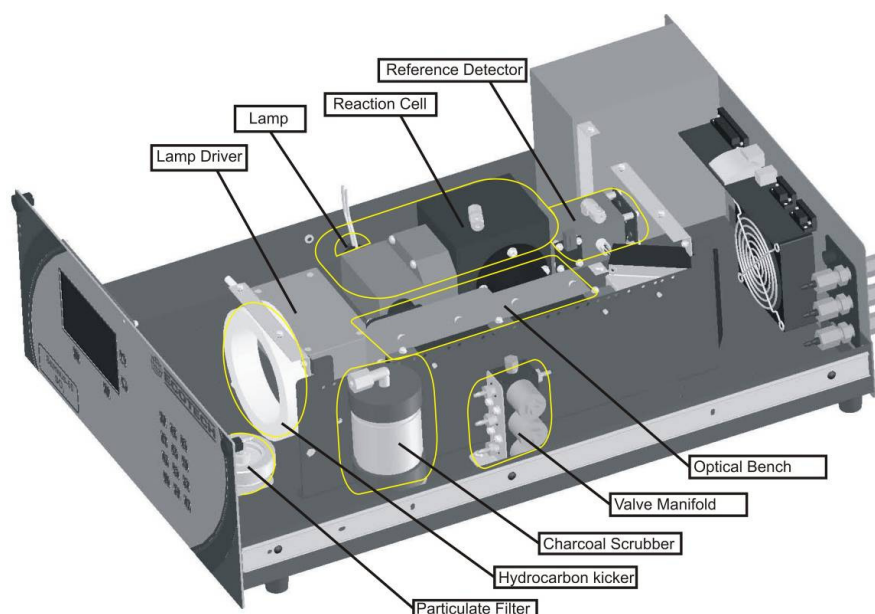

**Figure 3 Major Components**

---

### **1.5.1 Particulate filter**

---

The Particulate filter is a Teflon 5 micron ( $\mu\text{m}$ ) filter with a diameter of 47mm. This filter eliminates all particles larger than  $5\mu\text{m}$  and condensed water vapour that interfere with sample measurement.

---

### **1.5.2 Hydrocarbon Kicker**

---

The Hydrocarbon kicker removes interfering hydrocarbons from sample air. This is achieved by using counter current exchange, where an air with a lower concentration moves in an opposite direction to air with a higher concentration. The high concentration of hydrocarbons diffuse through a selective permeation membrane to the low concentration air and are removed with exhaust air. Increasing the flow of the low concentration air also increase the rate of diffusion.

---

### **1.5.3 Zero Air Scrubber**

---

A charcoal scrubber is used to produce SO<sub>2</sub> free air which is used in the hydrocarbon kicker to remove hydrocarbons from sample air.

---

**1.5.4 Reaction Cell**

---

**UV lamp**

The UV lamp is a discharge zinc UV lamp which emits UV radiation over a broad range

**UV Bandpass Filter**

The bandpass filter only allows UV at 214nm through into the cell.

**Photomultiplier tube**

The PMT detects the amount of light reaching its sensors. The filtering of light reaching the PMT allows direct measurement of SO<sub>2</sub> in the cell.

**Optical Bandpass Filter**

The optical bandpass filter is a colored glass that only allows light of a specific wavelength through (310-350nm)

**UV Grade Lenses**

Two UV grade silica lenses are used in the optical path, the first (plano-convex) to focus UV radiation inside the measurement cell and the second (bi-convex) focuses the fluorescent light onto the PMT cathode from the SO<sub>2</sub> reactions.

**UV Reference Detector**

The UV reference detector monitors the intensity of UV radiation entering the measurement cell. This measurement is used to compensate for variations in UV lamp output.

---

**1.5.5 Main Controller PCB**

---

The Main Controller PCB controls all the processes within the instrument, it contains a battery backed clock/calendar and an onboard microprocessor. The Main Controller PCB is located at the top of the instrument, above the rest of the components when lid is removed. The PCB is hinged and can be lifted up to stand up vertically allowing easy access to instrument components underneath.

---

**1.5.6 Reference detector Preamplifier**

---

This circuit board converts current signal from reference detector to a voltage signal and provide amplification.

---

**1.5.7 PMT High Voltage Supply and Preamplification**

---

This is a single component within the PMT housing. Its function is to supply high voltage to the PMT and to amplify the photocurrent signal from the PMT.

---

**1.5.8 Lamp Driver PCB**

---

This driver uses a high voltage and high frequency switching supply to start and maintain the UV lamp at a constant intensity. The lamp current is set by the microprocessor and is maintained at 30 mA.

---

**1.5.9 Pressure PCB**

---

The absolute pressure transducer is mounted to the measurement cell, and used to measure the sample pressure in the cell. This pressure is also used for the instrument to calculate flow.

---

**1.5.10 Power supply**

---

The power supply is a self-contained unit housed in a steel case designed to meet CE requirements.

It has a selectable input voltage of 115 or 230VAC 50/60 Hz and an output voltage of 12 VDC power for distribution within the analyzer.



**Note:** Input voltage can be manually changed by sliding the red switch left (230) for 220-240V or right (110) for the 100-120V. Ensure the switch is set to the correct voltage (from supply) before switching on.

**On/off switch**

Located on the back panel (bottom right facing from behind the instrument)

---

**1.5.11 Sulfur Dioxide scrubber**

---

The Sulfur Dioxide scrubber is a selective scrubber that captures SO<sub>2</sub> but allows H<sub>2</sub>S to continue through to the internal converter.

---

**1.5.12 Internal converter**

---

The internal converter uses high temperatures (300°C) and a catalyst to convert any H<sub>2</sub>S in the sample to SO<sub>2</sub>. This conversion is used for H<sub>2</sub>S measurements which have previously had the SO<sub>2</sub> portion scrubbed from it.

---

## 1.5.13 Communications

---

Communication between the analyzer and either a data logger, laptop or network can be performed with the following communication connections located on the back panel (see Figure 5).

### RS232 #1

This port is designed to be used for simple RS232 communication or with a Termination Panel allowing the Serinus instrument to work as a datalogger. This function is an optional extra and must be purchased from Ecotech.

### RS232 #2

This port is designed to be used for simple RS232 communication, or in a daisy chain (multidrop) configuration (multiple analyzers connected via the same RS232 cable).

### USB

This port can be used for instrument communication and is also good for quickly downloading data, onsite diagnostics and maintenance.

### TCP/IP (optional)

This port is best used for remote access and real-time access to instruments when a network is available to connect with.

### External I/O port

The Analog/Digital port sends and receives analog/digital signals to other devices. These signals are commonly used to activate gas calibrators or for warning alarms.

#### Analog Outputs

The analyzer is equipped with three analog outputs. Settable as either voltage output 0-5VDC, or current output 0-20,2-20,4-20 mA

#### Analog Inputs

The Analyzer is also equipped with three analog voltage inputs (0-5VDC) with resolution of 15 bits plus polarity.

**Warning:** Exceeding these voltages can permanently damage the instruments and void warranty

#### Digital Status Inputs

The analyzer is equipped with 8 logic level inputs (0-5VDC) for the external control of Zero/Span calibration sequences.

**Warning:** Exceeding these voltages can permanently damage the instruments and void warranty

#### Digital Status Outputs

The analyzer is equipped with 8 open collector outputs which will convey instrument status conditions and warning alarms such as no flow, sample mode, etc.



## 2 Installation

### 2.1 Initial check

#### Packaging

The packaging which the Serinus 51 is transported in is specifically designed to minimise the effects of shock and vibration during transportation. Ecotech recommends that the packaging be kept if there is a likelihood that the instrument is going to be relocated. For this purpose, it is also good to keep the red plastic caps installed in the pneumatic connections.

In the event that the packaging is to be disposed of, all the materials used are recyclable and should be disposed of accordingly.

Check the instrument with the following steps:

- Open instrument lid by using a screwdriver to undo the front quarter turn fasteners, also undo any further screws that may be installed in either the front or rear panel, then either slide the lid backwards (bench top)
- Check that all pneumatic and electrical connectors are connected, if not reconnect
- Check for any visible and obvious damage  
(if damage exists contact you supplier and follow the instructions in Claims for Damaged Shipments and Shipping Discrepancies page iv)

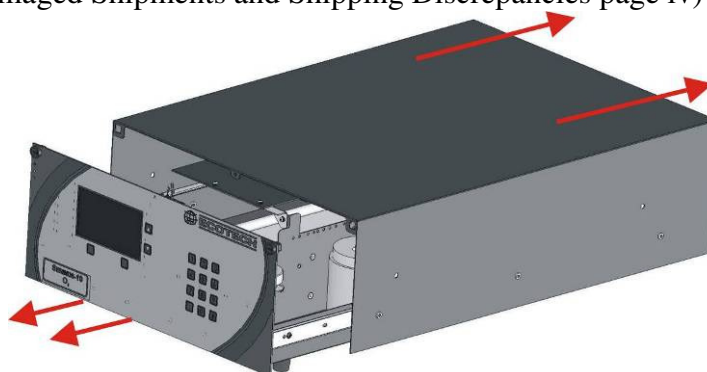

Figure 4 Opening the lid

#### Items Received

With the delivery of the Serinus 51, you should have received the following:

- |                                 |                |
|---------------------------------|----------------|
| • Ecotech Serinus 51 instrument | PN: E020050    |
| • Software CD                   | PN: S040001    |
| • End Caps                      | PN: B010002-02 |
| • Manual                        | PN: M010029    |
| • Power Cord (120V)*            | PN: 060-070110 |
| • Power Cord (240V)* Australia  | PN: 060-070140 |
| Europe                          | PN: 060-070120 |
| UK                              | PN: 060-070160 |

\*Power cord received depends on the power supply of the country (120V or 240V.).

**Please check that all these items have been delivered undamaged. If there is any item damaged or if you are unsure, please contact your supplier BEFORE turning on the instrument.**

## 2.2 Mounting/Siting

When installing the instrument the following points must be taken into account:

- Analyzer should be placed in an environment with minimal dust, moisture and variation in temperature (20-30°C for U.S. EPA designated range)
- For best results analyzers should be located in a controlled environment with temperature and humidity controlled (air conditioned shelter) set to 25-27°C
- Whether in rack or placed on bench instruments should not have objects placed on top of or immediately next to (touching) casing
- Instruments should be placed with easy access to front panel (instrument screen/USB flash) and to the back panel (Communications suite/pneumatic connections)
- It is recommended that sample line be as short as possible and/or a heated manifold be used for sampling (minimizing moisture condensation in sample)
- Do not pressurize sample line under any circumstances. Sample should be drawn through instrument from the atmosphere. This should be done either by and internal pump if installed or by an external pump connected to the exhaust port of the analyzer
- The power on/off switch is accessible from the rear of the instrument only. DO NOT mount such that the power on/off switch is inaccessible.



## 2.3 Instrument setup

When the Serinus has been mounted in a suitable site, the following sections must be followed to ready the analyzer for monitoring.

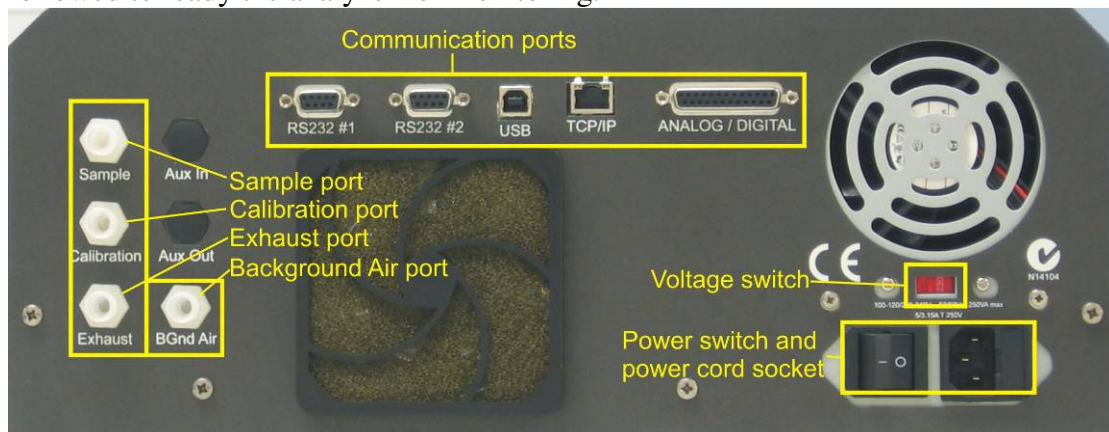

Figure 5 Instrument Back panel

### 2.3.1 Pneumatic connections

The Serinus 51 contains 4 pneumatic ports on the back panel of the analyzer; the sample port, the calibration port, the exhaust port and the background air port. All tubing and fittings used should follow the instructions below:

- Must be made of Teflon<sup>®</sup> FEP material, Kynar<sup>®</sup>, stainless steel, glass or any other suitably inert material
- Sample line should be no more than 2 meters in length with 1/8 inch ID, 1/4 inch OD

- Sample inlet pressure should not exceed 5 kPa above ambient pressure
- Tubing must be cut squarely and any burrs removed
- Remove nut, insert tubing through back of nut with tube extending 1 inch through front
- Place tubing into port until it hits the tube stop inside fitting
- Move nut onto fitting and tighten nut (clockwise) finger tight
- Nuts should be re-tightened when instrument reaches operating temperature

### Sample port

The sample port must be connected to an ambient source of sample air. When using a sample manifold the Serinus requires at least 1.5 slpm delivered to sample manifold (1.08 slpm for measurement plus approx 50% overflow).

### Calibration port

The calibration port should be connected to the span/zero source. It is recommended that a gas calibrator be used with SO<sub>2</sub> source to deliver precise concentrations of SO<sub>2</sub>.

### Exhaust port

The exhaust port is where the measured sample is expelled from the analyzer. The exhaust tubing should be fitted to a vacuum pump (minimum: 1 SLPM at 50 kPa), if the internal pump is not installed in your analyzer.

It is recommended that exhaust air is not expelled into a shelter/room inhabited by people, it should be expelled into the external air, away from the sample inlet.

---

## 2.3.2 Power connections

---

When connecting the power source the following must be adhered to:

**Warning**  
**The following points MUST be followed;  
incorrect setup and activation of instrument  
may cause damage and will void warranty**

- Verify that the red switch (above power switch) is switched to the correct setting (240V or 110V)
- A three pin power plug (with ground) **MUST** be used with an earthed power socket (3 pin)
- Connect the power plug into the mains power point and turn the power switch on

---

### 2.3.3 Communications connections

---

There are a number of different ways to communicate with the analyzer, select one of the following options

#### RS232 #1

- Connect this port to a Termination Panel with an RS232 cable.
- This port is also designed to be used with a Termination Panel allowing the Serinus instrument to work as a datalogger. This function is an optional extra and should be purchased from Ecotech.

#### RS232 #2

- Connect RS232 cable from instrument to computer, datalogger or in a daisy chain formation.

<b>Note:</b> When using daisy chain formations ensure each analyzer is given a unique instrument ID
---

- Configure computer/datalogger software for data export/remote control

#### USB

- Connect USB cable to computer and run either the Serinus data downloader program or WinAQMS logger

#### TCP/IP (optional)

- Plug in network cord (this cord should be attached to network)
- Use Remote data download program to access instrument and download data (supplied on utilities CD)

#### Analog/Digital

- This port is used to send/receive analog and digital signals. This port is normally used to connect with a gas calibrator, or to activate alarm signals.
- Contains 8 digital inputs, 8 digital outputs and 3 analog inputs and 3 analog outputs

---

### 2.3.4 Analyzer set up

---

- Ensure USB key is installed
- Check battery is turned on at main controller PCB (Figure 6)
- Turn on instrument and allow warm-up procedure to complete (section 3.1)
- Check/Set time and date (section 3.5.3)
- Set filter to desired monitoring option
- Set internal data logging options
- Set analog/digital inputs and outputs settings
- Leave instrument to warm up for 2-3 hours (CO over 3 hours), wait for a stable concentration measurement for at least 1 hour
- Perform span calibrations (see section 4.2) and a zero check (see section 4.6)
- Instrument will now be ready

## 2.4 Transporting/Storage

Transporting the Serinus should be done with great care. It is recommended that the packaging the Serinus was delivered in should be used for any transport as it ensures minimal damage to the instrument. When transporting or storing the instrument the following points should be followed:

- Turn off instrument and allow to cool down
- Remove all pneumatic, power and communication connections\*
- Remove instrument from rack
- Replace red plugs into pneumatic connections
- Place instrument back in plastic bag with desiccant packs and seal bag (Ideally the bag it was delivered in)
- Place back in foam and box instrument was delivered in if possible, if not find some equivalent packaging which provides protection from damage
- Instrument is now ready for long term storage or transportation

**Note:** After transport or storage, instrument must be set up and calibrated see section 2.3.4

\*if storing over long period (6 months) turn the battery off by switching the following switch on the main processor board (Figure 6) to the left

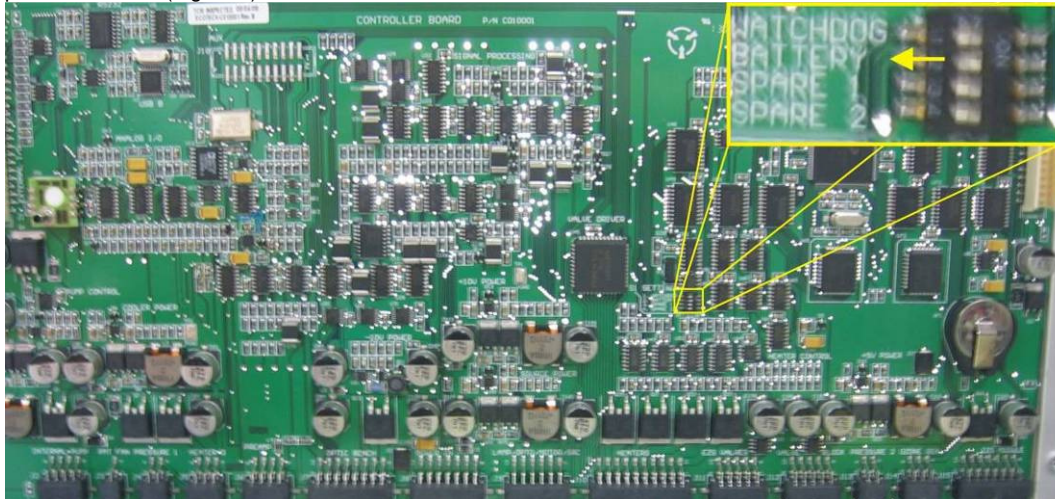

Figure 6. Switching battery off

## 3 Operation

### 3.1 Warmup

As the instrument is turned on it will adjust and calibrate itself ready for monitoring. No measurements are taken during the warm-up.

When the main screen appears, the instrument will display the following actions being taken (bottom of the screen):

#### High voltage check:

Instrument setting upper voltage limit for measurement

#### Lamp Stabilize

Adjusts the lamps current (27mA) for a stable (reference voltage) signal/output (10-15 minutes).

#### Ref stabilize

Adjusts the detector to set its maximum voltage output and create a stable output signal.

After this warm-up has completed the instrument will immediately begin taking measurements as seen in section 3.4.

### 3.2 General operational information

The Serinus is operated with the use of 3 sets of buttons. There are the selection buttons, scrolling buttons and keypad.

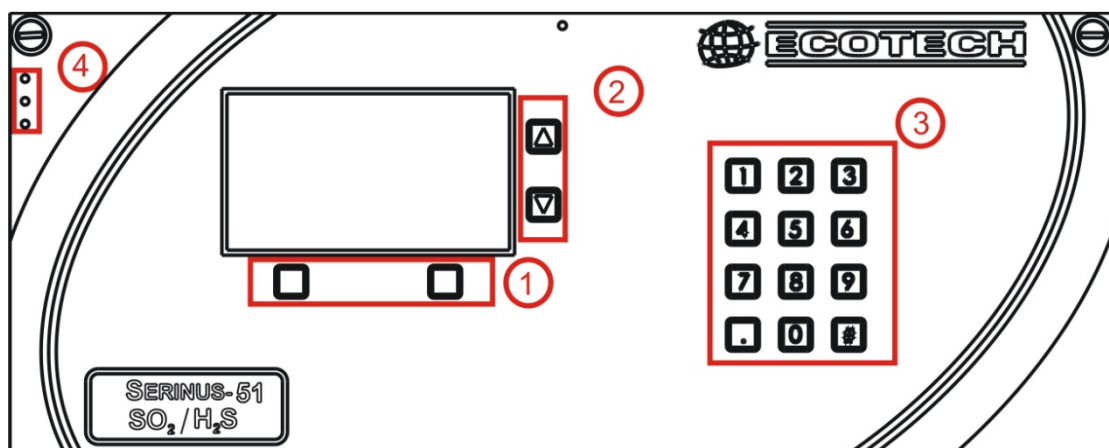

Figure 7 Serinus front panel

#### (1) Selection buttons

The selection buttons will perform the function specified directly above it on the screen i.e. quick menu, main menu, open, back, select, start etc

**(2) Scrolling buttons**

The scrolling buttons allow users to scroll up and down through menus. The scrolling buttons are also used to scroll side to side through editable fields (Date, time, concentration etc). On the main screen these buttons are used for adjusting contrast.

**(3) Keypad**

The keypad contains numbers 0-9, decimal point (.) and hash (#). The keypad is used to input numbers and concentrations when numbers on the screen are highlighted. In some circumstances the decimal point and hash are used for different functions (as explained on that specific screen).

**(4) Instrument status lights**

Located in the top left corner these lights indicate the status of the instrument as a whole.

- a. A red light indicated that the instrument has a major failure and is not functioning
- b. A yellow light indicates there is a minor problem with the instrument, but instrument may still take measurements reliably
- c. A green light indicates that the instrument is working fine and there are no problems

In the case of a yellow or red light enter the Main menu → Analyzer State → Status menu to find which components are failing (see section 3.5.2.1).

**3.3 Main screen**

The main screen is composed of 8 parts, the Readings, the Status/Error line, the time, the Instrument Activity line, menu buttons, the concentration units and USB detection. The contrast is adjustable only on the main screen, pressing the up scroll arrow will darken the screen; pressing the down scroll arrow will lighten it.

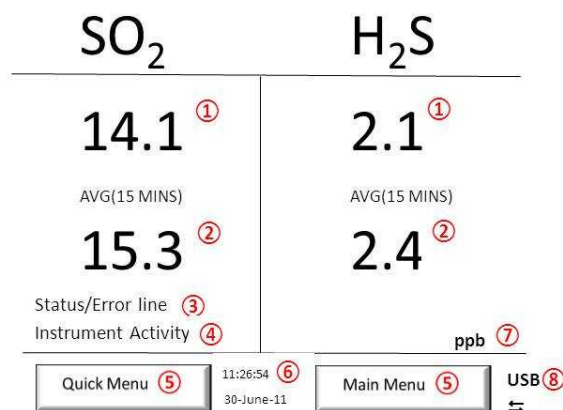

**Reading (1) Averages (2)**

The Reading and Averages section takes up most of the screen, it displays the concentration being measured in real time including during calibrations. When the instrument is changed in the Front screen field (General settings section 3.5.3) from “inst only” to “inst & avg” the reading will display both the average concentration (above) and the instantaneous concentration.

**Status/Error line (3)**

The Status/Error line provides users with information on any problems the instrument may have. It includes all the status/errors contained in the Status Menu section 3.5.2.1.

**Instrument Activity (4)**

The Instrument activity line shows what function the instrument is currently performing. This will generally be showing three groups of actions; Warm-up (section 3.1), Measurement (section 3.4) or Calibration (section 4).

**Menu buttons (5)**

The Menu buttons are used on the main screen to enter one of two menus. The Quick Menu (section 3.5.1) contains all information and features necessary in scheduled maintenance; the Main Menu (section 0) contains all information and fields available to users and is generally only used during initial setup.

**Time and Date (6)**

The Time and Date are displayed in between the menu buttons at the bottom of the screen. Time and Date are displayed as selected in section 3.5.3.

**Concentration Units (7)**

The current instrument units are displayed at the bottom right hand corner of the main screen.

**USB detection (8)**

A USB symbol will be displayed in the bottom right corner when the USB key is plugged in (behind front panel). If the USB symbol is not shown the USB key should be reattached. Underneath the USB symbols arrows may be displayed which indicates data transfer. The USB key should not be removed whilst this is happening.

**3.4 Sampling**

The Sampling performed by the Serinus 51 involves two cycles, an SO<sub>2</sub> cycle and a H<sub>2</sub>S cycle. The SO<sub>2</sub> cycle samples air directly from the valve manifold to the cell as per a standard SO<sub>2</sub> analyzer. The H<sub>2</sub>S cycle draws sample air firstly through an SO<sub>2</sub> selective scrubber to eliminate SO<sub>2</sub> and then a thermal converter which converts all the H<sub>2</sub>S into SO<sub>2</sub>. The sample is then analyzed in the cell. A background is performed once a day (normally leading up to midnight) and is used to measure background fluorescence in the cell and subtract it from sample measurements.

Sample fill (SO <sub>2</sub> )	Measurement cell fills with sample air (SO <sub>2</sub> )
Sample measure (SO <sub>2</sub> )	Measurement of sample air (SO <sub>2</sub> )
Aux fill (H <sub>2</sub> S)	Measurement cell fills with sample air (H <sub>2</sub> S)
Aux measure (H <sub>2</sub> S)	Measurement of sample air (H <sub>2</sub> S)

### 3.5 Menus and screens

The Menu system is divided into 2 sections, the Quick Menu and the Main Menu. The quick menu contains all information and operations necessary during scheduled maintenance visits. The main menu contains all fields that are accessible to users; they provide information on component failures, measurement parameters as well as editable fields and test procedures.

#### 3.5.1 Quick Menu

The quick menu is designed to contain all the tools for maintenance performed by operators in one easy to use screen. The quick menu allows operators to perform calibrations/checks, check important parameters and review service history in one menu.

##### *Span Calibrate*

This field is used to perform a span calibration. This option should be used only when a known concentration of SO<sub>2</sub> span gas is running through the measurement cell. When this is happening activate the span calibrate field, a window will open with editable numbers, change the numbers to match the concentration that the instrument is reading and select accept. The instrument span calibration has now been set.

##### *Zero calibrate*

This field is used to correct the zero calibration setting. This option should be used only when zero gas is measured by the instrument. When this is happening activate the zero calibrate field, a window will open with editable numbers, leave the numbers at 0000.000 and select accept. The instrument zero calibration has now been set. Note zero calibrations are generally not required as a background sequence should correct for zero drift.

##### *Event Log*

This field enters a screen with a log of all the events that the instrument performs. These events include calibrations, errors, backgrounds, warnings. This log is stored on the removable USB flash memory.

##### *Instrument*

This field allows the instrument to be set to either “Online” (Normal instrument operation) or “Offline” (data is not valid, as service work etc is being performed). This field is used to change the instrument into “Offline” when service work is being performed.

##### *Safely remove USB stick*

This feature must be activated before removing the USB memory to safely remove the USB stick (also occurs in the service menu 3.5.6). Failure to do this may cause corruption to the data on the memory stick.

***Gain***

A multiplication factor used to adjust the concentration measurement to the appropriate level (set at calibration)

---

## 3.5.2 Analyzer State

---

Displays the status of various parameters that effect instrument measurement and various functions. There are 4 sub menus within this menu and 3 non-editable fields described below.

### *Event Log*

This field enters a screen with a log of all the events that the instrument performs. These events include calibrations, errors, backgrounds, warnings. This log is stored on the removable USB flash memory.

### *Firmware Ver.*

This field displays the firmware version currently in use on this analyzer. This can be important when performing diagnostics and reporting back to the manufacturer.

### *Power Failure*

This field displays the time and date of the last power failure occurred (or power was disconnected from analyzer)

### 3.5.2.1 Status

The Component status menu contains a list of the main components within the instrument and their status.

#### *Cell Temp*

The cell temperature must be within  $\pm 10\%$  of the heater set point (section 3.5.3)

#### *Cooler Status*

Status of the PMT cooler,

#### *Sample Gas Flow*

Indicates whether the instrument has flow or not.

#### *A/D Input*

A reference voltage is sent to analog to digital input chip, this field will display a pass or fail indicating if the board is working or not.

#### *Chassis temp*

Displays whether the Chassis temperature is within the acceptable limits

#### *Reference Voltage*

Checks that the background is performing within acceptable limits  
Pass/Fail.

#### *Lamp/Source*

Checks if the Lamp current is between 20-50 mA. Pass if within these limits, Fail if outside.

#### *USB Key*

Detects whether a USB key is plugged into the USB port and instrument is logging

***Flow Block Temp (Optional internal pump only).***

If you have the optional internal pump this temperature must be within 10% of the heater set point (Section 3.5.3) to keep a constant accurate flow.

**3.5.2.2 Temperatures*****Set point (CELL)***

Sets the temperature that the heated components will be regulated at including the cell.

***Set point (CONVERTER)***

Sets the temperature that the converter will be regulated at.

***Temperature Units***

Editable field to allow the user to change the current temperature units of the analyzer.

***Cell***

Temperature of the reaction cell.

***Converter***

Temperature of the thermal converter.

***Flow block (optional internal pump only)***

If an internal pump is installed, this field displays the current temperature of the flow block.

***Chassis***

Displays the temperature of air inside the chassis, measured on the microprocessor board.

***PMT Cooler***

Temperature of the cooled PMT block

**3.5.2.3 Pressures & Flow*****Pressure units***

Select the units that pressure will be displayed in (torr, psi, bar, atm, kPa)

***Ambient***

Current ambient pressure (outside the analyzer).

***Cell***

Current pressure within the measurement cell

***Sample Flow***

Indicates the gas flow through the sample port of the instrument, should be around 0.70

<b>Note:</b> Will indicate 0.00 if the flow transducer senses flow has gone to zero.
--

**3.5.2.4 Voltages*****Conc Voltage (RAW)***

Voltage from the preprocessor proportional to the detected gas signal from the reaction cell. This voltage represents the actual measurement of gas.

***Ref Voltage***

Reference voltage as measured by the preamplifier board. This voltage is indicative of the UV lamp signal intensity.

***High Voltage***

PMT power supply high voltage reading

***Analog Supply***

+12 volt (primary) power supply.

***Digital Supply***

+5 volt microprocessor power supply.

***-10V supply***

-10 volt reading from the main controller board

---

### 3.5.3 General Settings

---

***Decimal Places***

Select “Edit” to change the amount of decimal places (0-5) used for concentration on the front screen

***Conc units***

Select the units that concentration will be displayed in (ppm, ppb, ppt, mg/m<sup>3</sup>, µg/m<sup>3</sup>, ng/m<sup>3</sup>).

***Temp units***

Select the units that temperature will be displayed in (°C, °F, K)

***Pressure units***

Select the units that pressure will be displayed in (Torr, Psi, Bar, atm, KPa)

***System Date***

The date can be entered in this screen by selecting “change” and using the keypad and scroll buttons to change date.

***System Time***

The time can be entered in this screen by selecting “change” and using the keypad and scroll buttons to change time (24 hour clock).

***Backlight***

Select how long the instrument backlight will stay on for (30 Secs, 1 Min, 2 Mins, 5 Mins, 10 Mins 30 Min 1 Hr Always On, Always Off)

***Front Screen***

This field allows the user to display concentrations on the front screen in two formats; the first is “Inst. Only” which displays only the instantaneous concentration reading, the second is “Inst & Avg” which displays both instantaneous and average concentration on the front screen

***Char 0 has slash***

Selecting enabled will ensure all zeros have a slash through them making them easily distinguishable from the letter O.

---

### 3.5.4 Measurement settings

---

***Average period***

Set the time period over which the average will be calculated: Minutes (1, 3, 5, 10, 15, or 30) or Hours (1, 4, 8, 12, or 24).

***Filter type***

Sets the type of digital filter used. Choices are: None, Kalman, 10 sec, 30 sec, 60 sec, 90 sec, or 300 sec.

***GasMeasure Cycle***

This field sets the time taken per measurement cycle i.e. 5 mins = 5 minutes for SO<sub>2</sub>, 5 minutes for H<sub>2</sub>S. The longer this time is set to the more stable readings will be, but the amount of readings per hour will decrease.

***Backgnd Interval***

Set time in HOURS (2, 4, 6, 8, 12, 24) or disabled. A microprocessor-controlled field that indicates when an auto zero cycle will begin. The results of the background are stored in the Event Log.

***Gas to Measure***

This field allows the operator to select whether the analyzer will only measure SO<sub>2</sub>, only measure H<sub>2</sub>S or measure both SO<sub>2</sub> and H<sub>2</sub>S.

***Noise***

The standard deviation of the concentration. The manner in which this is calculated is as follows:

1. Take a concentration value once every two minutes
2. Store 25 of these samples in a first in, last out buffer
3. Every two minutes, calculate the standard deviation of the current 25 samples. This is a microprocessor-generated field and cannot be set by the operator.

<p><b>Note:</b> This reading is only valid if zero air or a steady concentration of span gas has been fed to the analyzer for at least one hour.</p>
--

---

### **3.5.5 Calibration menu**

---

***Span Calibrate***

This field is used to correct the span calibration setting. This option should be used only when a known concentration of SO<sub>2</sub> span gas is running through the measurement cell. When this is happening activate the span calibrate field, a window will open with editable numbers, change the numbers to the concentration that the instrument is receiving and select accept. The instrument span calibration has now been set.

***Zero calibrate***

This field is used to correct the zero calibration setting. This option should be used only when zero gas is running through the measurement cell. When this is happening activate the zero calibrate field, a window will open with editable numbers, leave the numbers at 0000.000 and select accept. The instrument zero calibration has now been set. Note zero calibrations are generally not required as a background sequence should correct for zero drift.

***Manual Background***

Will display when the instrument is performing a background (running), when this is not the case press the start button to perform a manual background.

***Pressure calibration***

This field allows the user to calibrate the pressure sensors as explained in section 4.5

***Cal. type***

Select the “Calibration type” field and select either Timed or Manual. Timed calibration is an automatic calibration controlled by the

- Interval between cycles,
- Length of each calibration cycle,
- When the calibrations will begin from
- Whether the calibration will perform automatic compensation.

Manual calibration will perform a manual calibration depending on the calibration mode selected below.

**Note:** Timed calibration with span comp enable does not fulfill U.S. EPA approval

***Cal. Port***

Select whether the instrument will sample from the external span/zero source (Calibration port) or from the internal span/zero source (IZS)

***Span Compensation***

When “enabled” the instrument will adjust the gain from the span concentration, when set to “disabled” instrument gain won’t be updated.

***Cal. Pressure***

This field displays the measured pressure during the last calibration (for SO<sub>2</sub> reference)  
reference)

***Cal Temperature***

Temperature at which the instrument performed its last span calibration

***H2S efficiency***

The efficiency that the converter converts H<sub>2</sub>S into SO plus losses in the selective SO<sub>2</sub> scrubber.

=====

**MANUAL MODE**

=====

***Cal. mode***

When in Manual mode the instruments operational mode can be chosen from the following:

- Measure: is the normal measurement through the sample port

- **Cycle:** performs a zero, then a span then returns to measure mode. The length of time spent measuring calibration gases is set in cycle time (below)
- **Span:** this mode will take air through the calibration port so that a span calibration can be performed
- **Zero:** this mode will take air through the calibration port so that a zero calibration can be performed

=====

**TIMED MODE**

=====

- Date**            Enter the date for the first calibration (will display next calibration time after the first calibration is complete)
- Time**            Enter the time (during the day above) that calibrations will be performed
- Repeat**        Sets the amount of time between each calibration (from the above time and date)

<p><b>Note:</b> The units of the repeat interval can be changed by pressing the # key (minutes, hours, days)</p>
--

***Span Cal Level***

Enter the concentration of span gas used during the timed span calibrations.

***Cycle time***

Set the time period that the zero and span calibrations will last for during Timed Calibration (1 to 59 minutes).

---

### 3.5.6 Service

---

The Service Menu is information used to diagnose problems or suspected problems. The settings return to the previously set conditions when the operator leaves this menu.

***Diagnostics***

See section 3.5.6.1

***Calculation factors***

See section 3.5.6.2

***Save Configuration***

Saves instrument EEPROM settings to USB key including (calibration and communication settings, units, instrument gain etc). If you have problems with your instrument use this function to save setting to the removable USB stick and send them to your supplier with your service enquiry.

***Save parameter List***

Name the file which the parameter settings will be downloaded into (at that time), used for diagnostics

***Load Configuration***

Loads instrument EEPROM setting from USB key (including calibration and communication settings, units, instrument gain etc).

***Auto-Backup Interv***

The Param list and config file are saved onto USB for the duration set in this field

***Load Auto-Backup Config***

Loads up the last auto backup configuration (best used when configuration has been changed in error)

---

***Instrument***

This field allows the instrument to be set to either “Online” (Normal instrument operation) or “Offline” (data is not valid, as service work etc is being performed). This field is used to change the instrument into “Offline” when service work is being performed.

***Next service due***

An editable field where the user can set the date when the next instrument service is required. Section 6.3 has a recommended maintenance schedule that may be used as a basis for the interval entered above. This value is also displayed as a non editable field in the quick menu section 3.5.1.

***Rebuild event Log Index***

This feature will rebuild the logs on the USB key. This is necessary when any changes to the files or folders on the USB key have been made (including within a file). Rebuilding the log index will re-index all the contents and thus allow the instrument to view error logs.

***Safely remove USB stick***

This feature must be activated to safely remove the USB stick (also occurs in the quick menu 3.5.1).

***System Restart***

Activating this will reboot the microprocessor. This action is useful when uploading new firmware or if tests are being carried out.

---

***Avg conc.***

Displays the SO<sub>2</sub> / H<sub>2</sub>S average concentration

### 3.5.6.1 Diagnostics

The Diagnostics menu provides a large variety of features that allow the user to investigate problems with the analyzer or gain a greater insight into what the instrument is doing. This Menu contains 3 sub menus and 3 editable fields, the 3 editable fields are presented directly below for your convenience and the sub menus after them.

#### 3.5.6.1.1 *Pres/temp/flow Comp*

Set to either On or Off.

On is used to compensate analyzer measurements for environmental fluctuations that might affect readings (pressure, temperature and flow).

Off is used only when running diagnostics to see fluctuations in readings.

#### 3.5.6.1.2 *Diagnostics mode*

The instrument can be placed in 4 diagnostic modes:

- Operate which leaves the instrument in normal operation mode
- Optic which configures the instrument for tests on the optical measurement source
- Electrical which configures the instrument for testing of the electrical circuits
- Preamp which configures the instrument for testing of the pre-amplification circuitry

#### 3.5.6.1.3 *Control loop*

When “enabled” the instrument will control all processes within the instrument.

- Selecting Disabled will pause the instruments control over certain processes and parameters (digital pots, internal pump etc). The user can now manually alter and adjust digital pots.
- When instrument is put back in “Enabled” mode or taken back to main screen the new pots will be set and instrument will resume control over pots.

#### 3.5.6.1.4 *Digital pots*

Preprocessor pots are electronically controlled digital potentiometers used for adjustments to operations of the analyzer. Each pot is set with digits 0 to 255 in a non-wraparound scrolling field.

<b><i>High Volt Adj</i></b>	<i>(145-165)</i>
<b><i>High Voltage</i></b>	<i>(690-715)</i>
<b><i>Lamp Adjust</i></b>	<i>(50-200)</i>
<b><i>Lamp Current</i></b>	<i>(21-36)</i>
<b><i>PGA Gain</i></b>	<i>(1-128)</i>
<b><i>Input pot</i></b>	<i>(128)</i>

<i>Meas. Zero</i>	(25-150)
<i>Conc Voltage (RAW)</i>	(0-3)
<i>Conc Voltage</i>	(0-3)
<i>Ref. Zero</i>	(0)
<i>Ref. Gain -.</i>	(10-100)
<i>Ref. Voltage</i>	(1.7- 3.5)
<i>Test Pot</i>	(0)

### 3.5.6.1.5 Valve menu

The valve menu allows the user to observe the opening and closing of valves as well as opening and closing them manually.

#### *Valve sequencing*

When set to “on” the instruments valves will switch as normal, when set to “off” the instrument will hold the valves in their current formation and valves can be opened and closed via the above fields.

**Note:** valve sequencing will remain off unless the instrument has returned to main screen for over 2 minutes.

#### *Span/Zero select*

Shows the action of the valve that determines whether Sample gas or Calibration gas/internal zero air is being sampled (Open = Span/Zero, Closed = Sample gas).

#### *Cal Port Select*

Shows the action of the valve that determines whether the instrument calibration gas is taken from the Calibration port or the Internal Zero

#### *Pressurised Span (OPT)*

Shows the action of the valve that determines whether the instrument calibration gas is taken from the optional pressurised span port

#### *Pressurised Zero (OPT)*

Shows the action of the valve that determines whether the instrument zero air calibration gas is taken from the optional pressurised zero air port

### 3.5.6.1.6 Tests

#### *Screen test*

Will perform a screen test by activating lines on the screen so that the operator can determine if there are any faults in the screen

***Digital Inputs***

This menu item allows the user to set which pin the power source is located on and also displays the pins that digital inputs are located on.

**Note:** Changes performed with this item will disrupt the normal logging

***Digital Outputs***

This menu item allows the user to view the pins that digital outputs are located on

**Note:** Changes performed with this item will disrupt the normal logging

***Analog Inputs & Outputs***

Displays the pins that analog inputs are located on and allows the user to set the analog outputs

**Note:** Changes performed with this item will disrupt the normal logging

**3.5.6.2 Calculation factors**

The Calculation factors screen provides a list of calibration values used by the instrument to generate valid data. The operator can collect these values and report them on calibration reports as part of their quality assurance.

***Instrument gain***

A multiplication factor used to adjust the concentration measurement to the appropriate level (set at calibration)

***Zero Offset***

This field displays the offset created from a zero calibration, this is the concentration measured from zero air and is subtracted from all readings.

***Background***

The correction factor calculated from the background cycle (used to eliminate background interferences).

***P/T/F Correction***

Displays the correction factor applied to the concentration measurement. This factor corrects for changes in pressure, temperature and flow.

***H2S efficiency***

The H2S efficiency value is derived from the losses associated in the selective SO<sub>2</sub> scrubber and H<sub>2</sub>S to SO<sub>2</sub> conversion.

***P/T/F Correction (H2S)***

Displays the correction factor applied to the H<sub>2</sub>S concentration measurement. This factor corrects for changes in pressure, temperature and flow.

---

**3.5.7 Communications**

---

**3.5.7.1 Analog Output Menu**

*The analogue output menu is split into two sections, one for each measurement parameter (SO<sub>2</sub>, H<sub>2</sub>S). The following fields are found in one or all of these sections.*

***Output type***

Sets the output to be either current or voltage

***Range***

Set upper range limit (in concentration units) to desired SO<sub>2</sub> and H<sub>2</sub>S concentration. This value cannot exceed the “Over Range” value.

***Over-ranging***

Set to “Enabled” or “Disabled” to turn the over-ranging feature on or off.

***Over Range***

This field is only visible when Over-ranging is set to enabled. Set to desired over range value. This value cannot be set below the RANGE value. This is the alternate scale the recorder or DAS indicates when over-ranging is active and enabled. (When 90% of the set range is reached, this auto range is effective. When 80% of the original range is reached, it returns to the original range.)

***Current range (Current only)***

Choose the range that the current will be offset by (0-20, 2-20, 4-20)

***20mA calibration (Current only)***

Enables the user to calibrate the current output at a full scale point

***4mA Calibration (Current only)***

Enables the user to calibrate the current output at a low point

**3.5.7.2 Data Logging Menu*****Data Log Setup –Quick***

Allows up to 15 parameters to be logged. After each parameter (labelled “Logging Param. 1” – “Logging Param. 15”) place the number of the parameter that is to be logged found in:

- Appendix A Advanced Protocol Parameter List for parameter number list

- Data Log setup –GUI below

#### ***Data Log setup –GUI***

This field works in tandem with the “Data Log setup –Quick” field and is used when the parameter number is not known. The user can enter each logging parameter field (P1-P15) and scroll through all the parameters that can be logged. Once the parameters to be logged has been filled out, the parameter numbers can be copied from within the “Data Log Setup –Quick” field for future use.

#### ***Data Log Interval***

Set the interval (length) of time that measurement data will be logged over i.e. 1 minute data, 5 minute data etc

### **3.5.7.3 Serial Communications**

#### ***Multidrop ID***

The ID address of the analyzer when Multidrop RS232 communications is used.

#### ***Baud (RS232 #1)***

Set the Baud rate that the instrument will communicate over (1200, 2400, 4800, 9600, 14400, 19200, 38400)

#### ***Protocol (RS232 #1)***

Set the protocol used for communication either EC9800, Bavarian or Advanced

#### ***Baud (RS232 #2)***

Set the Baud rate that the instrument will communicate over (1200, 2400, 4800, 9600, 14400, 19200, 38400)

#### ***Protocol (RS232 #2)***

Set the protocol used for communication either EC9800, Bavarian or Advanced

#### ***Delay (RS232#2)***

When set to “enabled” will delay the serial communication through the RS2323 #2 port by approximately 0.25 seconds, this is used in systems that cannot cope with the rapid response of the Serinus instruments. When set to “disabled” communication will proceed as normal.

### **3.5.7.4 Digital Inputs Menu**

Assign the digital input 0-7

### **3.5.7.5 Digital Outputs Menu**

Assign the digital outputs 0-7



## 4 Calibration

### 4.1 Zero Calibration

Zero calibrations are used to set the zero point of the analyzer.

**Note:** This calibration is unnecessary in most situations and should only be performed if required. Ecotech recommends that zero calibration not be used unless specifically required.

Performing a zero calibration can be performed through either the Calibration port or Sample port. Follow the relevant instructions below:

#### Calibration port

1. Ensure suitable zero air source is connected to the “Calibration port” on the back panel of analyzer (see section 2.3.1)
2. Enter the Main Menu → Calibration Menu → Calibration Mode
3. Select the Calibration mode to be zero
4. Allow the instrument to stabilize (15 minutes)
5. Enter the Quick Menu and select “Zero Calibration”
6. A box will appear with editable numbers, select 0.00
7. Instrument will perform Zero calibration, when finished the instrument will return to normal activities

#### Sample port

1. Ensure suitable zero air source is connected to the “sample port” on the back panel of analyzer (see section 2.3.1)
2. Let the instrument stabilize
3. Enter the quick menu and select “Zero Calibration”
4. A box will appear with editable numbers, select 0.00
5. Instrument will perform Zero calibration, when finished the instrument will return to normal activities

### 4.2 Span Calibration

Performing a span calibration can be performed through either the Calibration port or Sample port. Span calibrations calibrate the instrument to the upper limits of normal monitoring. Ecotech recommends that 80% of full scale should be sufficient for calibrations in ambient monitoring situations 100 ppb. Follow the relevant instructions below:

#### Calibration port

1. Ensure suitable span gas (SO<sub>2</sub>) source is connected to the “Calibration Port” on the back panel of analyzer (see section 2.3.1)
2. Enter Main Menu → Measurement Settings menu → Gas to Measure and set this field to SO<sub>2</sub>
3. Set the span source to a known concentration (80% full scale recommended)
4. Enter the Main menu → Calibration menu → Calibration mode
5. Select the Calibration mode to be span
6. Let the instrument stabilize (15 minutes)

7. Enter the quick menu and select “Span Calibration”
8. A box will appear with editable numbers, select the concentration being delivered to the instrument
9. Instrument will perform Span calibration, when finished the instrument will return to normal activities

### Sample port

1. Ensure suitable span gas (SO<sub>2</sub>) source is connected to the “Sample Port” on the back panel of analyzer (see section 2.3.1)
2. Enter Main Menu → Measurement Settings menu → Gas to Measure and set this field to SO<sub>2</sub>
3. Set the span source to a known concentration
4. Let the instrument stabilize (15 minutes)
5. Enter the quick menu and select “Span Calibration”
6. A box will appear with editable numbers, select the concentration being delivered to the instrument.
7. Instrument will perform Span calibration, when finished the instrument will return to normal activities

## 4.3 H<sub>2</sub>S Efficiency

After a span calibration has been performed follow this procedure to accurately determine the H<sub>2</sub>S (converter and scrubber) efficiency.

1. Ensure the H<sub>2</sub>S efficiency is set to 100%
2. Connect a source of H<sub>2</sub>S span gas to the calibration port
3. Enter Main Menu → Measurement Settings menu → Gas to Measure and set this field to H<sub>2</sub>S
4. Allow H<sub>2</sub>S readings to stabilize (30 minutes) and record the concentration displayed on the main screen.
5. Set the span source to a known concentration (80% full scale recommended)
6. Calculate the H<sub>2</sub>S efficiency by dividing the recorded concentration with the expected concentration i.e. expected = 100ppb, recorded = 80 ppb  
 $80/100 = 80\%$  H<sub>2</sub>S efficiency
7. Update the H<sub>2</sub>S efficiency in the following menu: Main menu → Calibration menu → H<sub>2</sub>S Efficiency
8. Return the instrument setting for normal measurement i.e. Gas to measure field

## 4.4 Multipoint Calibration

The multipoint involves supplying the instrument with span gas at multiple known concentrations and recording the output of the instrument. Multipoint calibrations are used to determine the linearity of concentration curve; the instrument gain should not be adjusted to each individual point.

1. Ensure a suitable span source is connected to instrument from a gas calibrator (Ecotech recommends the GasCal 1100) through the sample port
2. Record analyzer instrument gains before performing calibration (section 3.5.1)

3. Perform a zero calibration as described in section 4.1
4. Perform a span calibration as described in section 4.2
5. Set up a program for measuring the span concentration through 5 steps down from 80% of full scale

Example for full scale of 100ppb

- a. Set the 1<sup>st</sup> concentration on the gas calibrator to 80ppb, allow instrument to sample for 15 minutes, record measurement.
- b. Set the 2<sup>nd</sup> concentration on the gas calibrator to 60ppb, allow instrument to sample for 15 minutes, record measurement.
- c. Set the 3<sup>rd</sup> concentration on the gas calibrator to 40ppb, allow instrument to sample for 15 minutes, record measurement.
- d. Set the 4<sup>th</sup> concentration on the gas calibrator to 20ppb, allow instrument to sample for 15 minutes, record measurement.
- e. Set the 5<sup>th</sup> point at a concentration of 0ppm (zero air); allow the instrument to sample for 15 minutes and record measurement.

6. The linearity and correlation can be calculated for each point manually or all points calculated within excel

### 7. Manual Calculations

Record the concentration measurement at each point and determine the percent difference between instrument response and the supplied concentration using the following equation

$$\frac{\text{Instrument Response} - \text{Supplied Concentration}}{\text{Supplied Concentration}} \times 100 = \text{Percent Difference}$$

Equation 1 Instrument accuracy

8. If the difference between values is less than 1% then the instrument is within specifications. Otherwise a Leak Check and or service are required

### 9. Microsoft Excel

Alternatively all the data can be placed in an excel spreadsheet in columns next to the supplied concentration.

10. Create an X Y scatter plot of expected calibration against instrument response, right click on either point and select "Add Trendline". Tick the "Display equation on chart" and "Display R-squared value on chart" in the options tab
11. The linear regression equation  $y = mx + b$  will be displayed

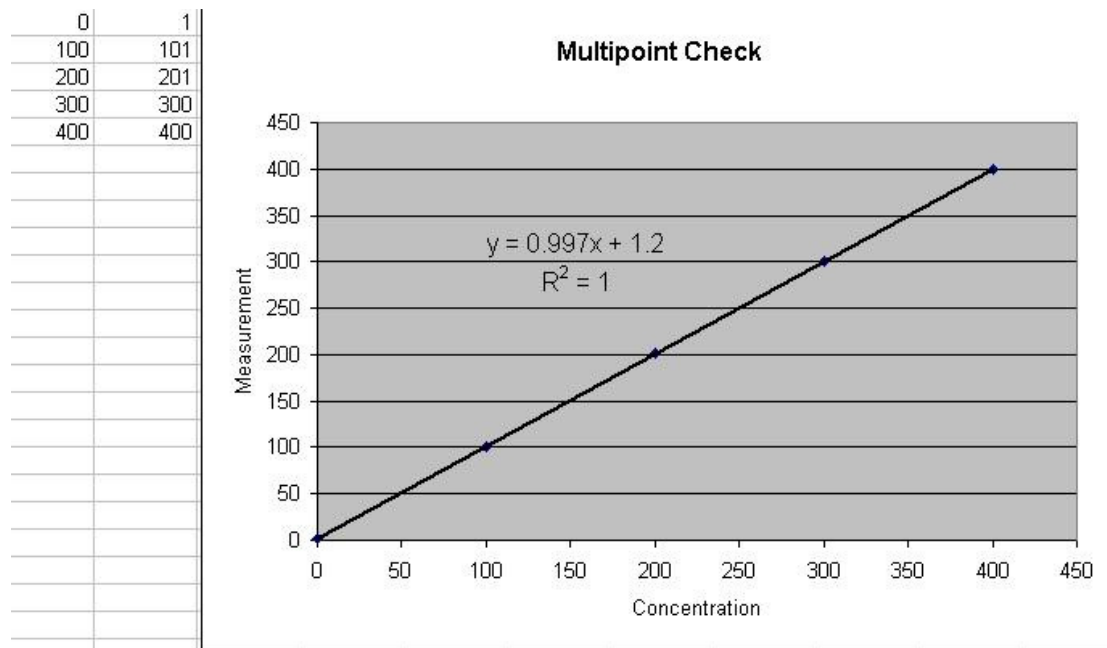

**Figure 8 Excel graph of Multipoint Calibration**

12. Accept the calibration if the following are found:
- The gradient (m) falls between 0.98 and 1.02
  - The intercept (b) lies between  $\pm 0.3$ .
  - The correlation ( $R^2$ ) is greater than 0.9995
13. Reject the calibration if the above criteria are not met. If the calibration fails perform a leak check (section 6.4.5), check zero air scrubbers or check troubleshoot guide for possible errors (section 7).

## 4.5 Pressure calibration

The pressure calibration involves a two point calibration, one point under vacuum and another point at ambient pressure. This procedure is necessary when all settings have been wiped, when pressure readings are faulty or for diagnostic purposes. To perform a pressure calibration the following steps must be completed

**Note:** The vacuum calibration must be performed first when performing a pressure calibration

### Vacuum

1. Open instruments (section 2.1)
2. Unscrew fitting from top of cell, anticlockwise, remove 1/8 black tubing and screw stainless steel blocker onto fitting (1 in Figure 9)
3. Remove tubing (connecting to hydrocarbon kicker) from cell T-piece (2 in Figure 9)
4. Connect pressure meter onto cell T-piece and measure pressure

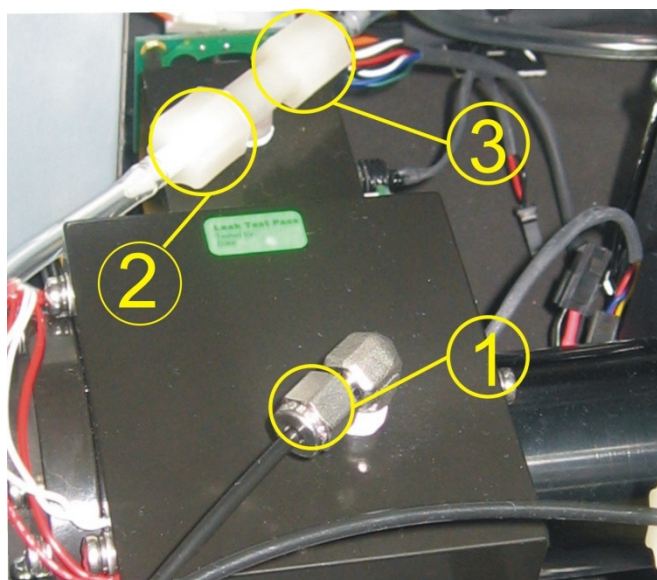
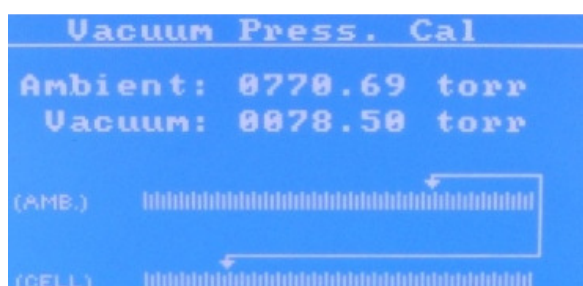

Figure 9 Pressure Calibration

5. Connect vacuum source to exhaust port of analyzer,.
6. Enter Calibration menu → Pressure Calibration and select pressure (vacuum pressure) then select the unit of pressure being used (torr etc)
7. The screen will display two horizontal bar (Figure 10) the first (Amb) is for the ambient pressure sensor, the second (Cell) is for the cell pressure sensor
8. Ensure that the pressure is stable (arrows are not moving up and down the bar).



**Figure 10 Pressure menu**

9. Select the set option (activate buttons) the Current Pressure window will open
10. Using the keypad, input the current pressure reading on the meter.
11. Press the “Accept” button to calibrate pressure sensors

**Ambient**

1. Continuing from the Vacuum calibration, remove the pressure meter from the cell fitting
2. Remove the stainless steel blocker from the cell T-piece fitting (3 in Figure 9)
3. Switch off and disconnect any vacuum sources from the Exhaust port.
4. Measure the ambient pressure from the meter
5. Enter the main menu → Calibration menu → Pressure calibration
6. Select ambient (ambient pressure) then select the unit of pressure being used (torr etc)
7. The screen will display two horizontal bars (Figure 10) the first (Amb) is for the ambient pressure sensor, the second (Cell) is for the cell pressure sensor
8. Ensure that the pressure is stable (arrows are not moving up and down the bar.
9. Select the set option (activate buttons) the Current Pressure window will open
10. Using the keypad, input the current pressure reading on the pressure meter in ambient air.
11. Press the “Accept” button to calibrate pressure sensors
12. Reconnect tubing to cell as shown in 1 +2 Figure 9

**4.6 Precision check**

A precision check is a Level 2 calibration. This means that the instrument has a known concentration, or zero air, run through it and an observation of the instruments concentration is made with no adjustment. A precision check can be performed either manually or automatically.



## 5 Communications

The Serinus analyzer has four methods of communication. Each communication method is used in specific situations for data download, instrument control or both. The Serinus can perform communication through 4 different paths (RS232, USB, 25 pin Digital/Analog input/output or TCP/IP network (optional)). The Serinus also includes a windows application, the Serinus Communicator, that allows data download and remote activation from a PC.

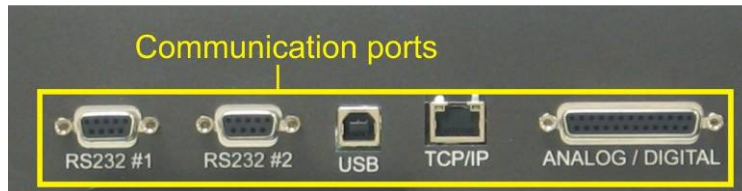

Figure 11 Communication ports

### 5.1 RS232 Communication

#### RS232 #1

This port is designed to be used with a Termination Panel allowing the Serinus instrument to work as a data logger. This function is an optional extra and must be purchased from Ecotech.

#### RS232 #2

RS232 communication is the most reliable way to access data from instrument. RS232 port #2 should be connected to a computer, datalogger or in a daisy chain configuration (multiple analyzers connected via the same RS232 cable).

Uses the following protocols

- EC9800 protocol (Appendix B)
- Bavarian protocol (Appendix C)
- Advanced (Appendix D)

### 5.2 USB Communication

#### USB

This port is ideal for downloading data quickly via a laptop and for onsite diagnostics and maintenance.

### 5.3 TCP/IP Network Communication

#### TCP/IP (optional)

This port is best used for remote access and real-time access to instruments when a network is available to connect with.

#### Installation

1. If **Device Installer** is not installed on your PC, download it from <http://www.lantronix.com/device-networking/utilities-tools/device-installer.html>

2. The Serinus analyzer must be configured to allow network use, this is done through directly connecting it with a PC. Using a crossover Ethernet cable, connect the cable from the Ethernet port on the Serinus to a free Ethernet port on the PC.

**Note:** This step requires a free Ethernet port on the PC. If Ethernet port is being used to connect to the network, stop all network activities and disconnect the cable.

3. Wait until the connection between the Serinus and the PC gives the status “Limited or no Connectivity” as seen on the PC. This should take a few minutes.
4. Open **Device Installer**. If a message box comes up asking you to view a TCP/IP tutorial (Figure 12), click No.

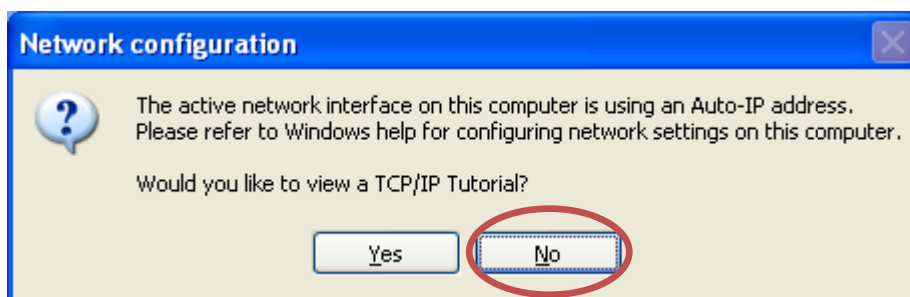

**Figure 12 Device Installer pop up window**

5. When initial search has completed, access the XPort-03 device listed on the right-hand pane (Figure 13) by double-clicking on it. This will bring up its details.

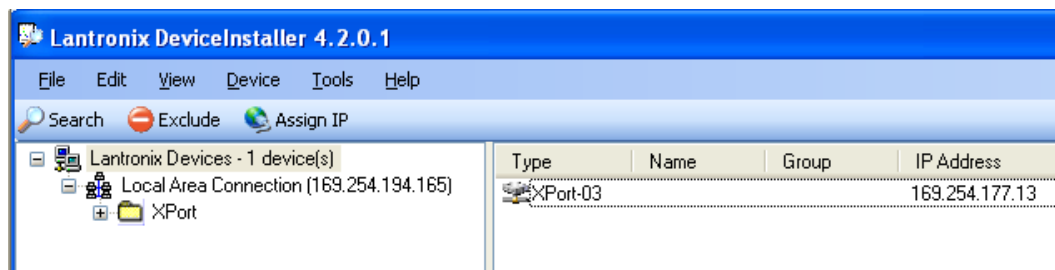
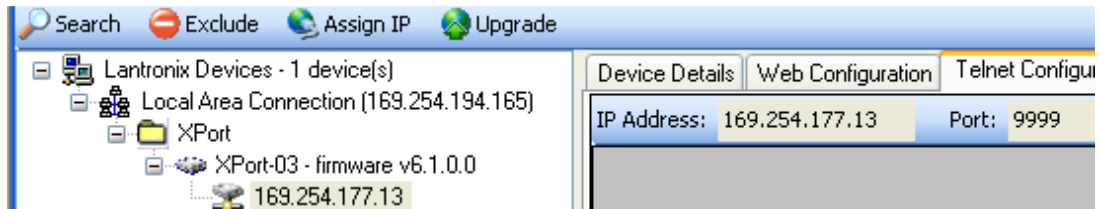

**Figure 13 Device Installer XPort-03**

6. If the XPort-03 details do not immediately appear follow the steps below

- a) On the Serinus analyzer enter the Network Adaptor Menu (Main → Communications → Network Adaptor)
- b) Change the “Operation “ field from **Normal** to **Read IP Config**
- c) Restart the Serinus instrument
- d) Return to the Network adaptor menu and record the IP address displayed
- e) On your PC change the IP address so that it is in an accessible range to that of the instrument (e.g. Serinus IP address = 169.254.177.48, PC IP address = 192.168.253.1). To change IP address on PC → Local Area connections → Properties → Internet Protocol → Properties
- f) Now the XPort-03 will be displayed within the Lantronix Device Installer

7. Click the “Telnet Configuration” tab and click “Connect” (Figure 14). Leave the IP address and port as is. Afterwards, press Enter to enter Setup Mode. This will list the various parameters set up in the Serinus and will give you menu options to change them.



**Figure 14 Device Installer - Telnet Configuration**

8. On the “Change Setup” menu, Press 0 and then Enter to Open the Server setup
  - a) Press Enter to accept current IP Address value or type in new value (must press enter after each number is entered)
  - b) Press “Y” to set Gateway address (this value should be obtained from your network administrator) and enter Gateway address
  - c) Set the number of Netmask bits e.g.
 

24	255.0.0.0
16	255.255.0.0
8	255.255.255.0
  - d) When it asks you to “Set password” select N
9. On the “Change Setup” menu, Press 1 and then “**Enter**” to open the Channel 1 setup (below).

```

Change Setup:
  0 Server
  1 Channel 1
  3 E-mail
  5 Expert
  6 Security
  7 Defaults
  8 Exit without save
  9 Save and exit
                                Your choice ? 1
  
```

10. Change the settings to match those in brackets below as they appear. The value in brackets indicates its current configuration. If the value should be left unchanged, simply press Enter without any value being entered (below).

```

Baudrate (38400) ?
I/F Mode (4C) ?
Flow (00) ?
Port No (32785) ?
ConnectMode (C0) ?
Send '+++ ' in Modem Mode (Y) ?
Auto increment source port (N) ?
  
```

```
Remote IP Address : (000) . (000) . (000) . (000)
Remote Port      (0) ?
DisConnMode     (00) ?
FlushMode       (00) ?
DisConnTime     (00:00) ?:
SendChar 1      (00) ?
SendChar 2      (00) ?
```

**Settings available during Channel 1 setup**

11. When returned to the “Change Setup” menu, press 9 then Enter to save the settings.

**5.4 Digital/Analog communication**

**External I/O port**

The 25 Pin Analog/Digital port on the rear of the analyzer sends and receives analog/digital signals to other devices. These signals are commonly used to activate gas calibrators or for warning alarms.

**Analog Outputs**

The analyzer is equipped with three analog outputs Voltage 0-5V or Current settable 0-20,2-20,4-20 mA

**Analog Inputs**

The Analyzer is also equipped with three analog inputs with resolution of 15 bits plus polarity. Input voltage 0-5 V

**Digital Status Inputs**

The analyzer is equipped with 8 logic level inputs for the external control of the Analyzer such as Zero/Span sequences. Each input has a terminating resistor which can be either PULL UP or PULL DOWN. This is set using the Jumper JP1 on the Back Panel printed circuit board.

**Digital Status Outputs**

The analyzer is equipped with 8 open collector outputs which will convey instrument status conditions warning alarms such as no flow, sample mode, etc. Two of the digital outputs can be set so that there is +5V or +12V available on the 25 pin connector for control purposes.

In the default jumper locations (Figure 15) these two outputs will function normally as open collector outputs. If moved to the position closer to the 25 pin connector then DO 0 will supply +12V and DO 1 will supply +5V. These supplies are limited to about 100mA.

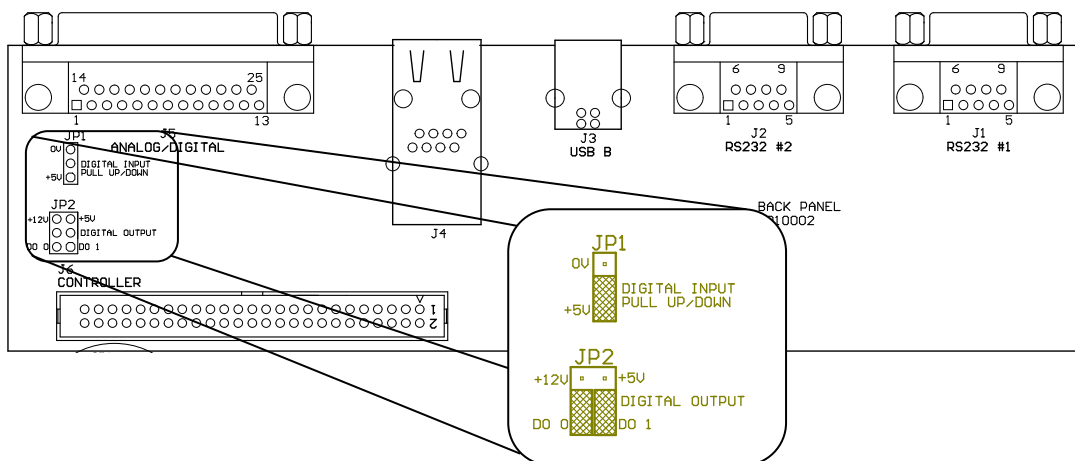

**Figure 15 Serinus 25 pin microprocessor board (with default jumpers highlighted)**

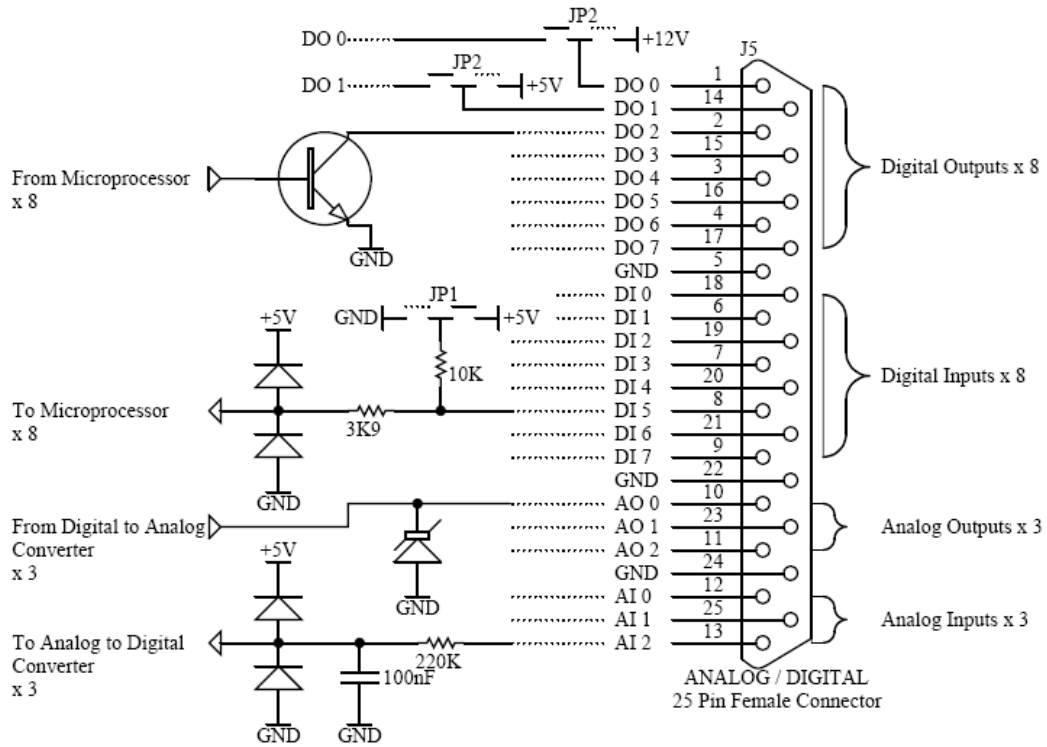

Figure 16 External 25pin I/O individual pin descriptions



**Warning:** The Analog and Digital Inputs and Outputs are rated to CAT I, meaning that they should be less than 12VDC. Exceeding these voltages can permanently damage the instruments and void warranty

## 5.5 Serinus downloader program

The Serinus Downloader program is designed to allow the user to acquire data directly from the analyzer and control it remotely. The Serinus downloader program has four main windows; “**Settings**” where configurations are made to communicate with the analyzer, “**Data**” where data is downloaded into a spreadsheet and “**Remote Screen**” where the analyzer can be controlled directly and “Remote Terminal” which is a diagnostic tool used to check instrument operation and parameter values.

### 5.5.1 Settings

Within this window both the data format setting and analyzer communications settings are defined. There are two icons in the main header, they are **Save Settings** (which saves the current settings as default) and Cancel changes

#### Output

**Output file:** Enter in the destination (folder) including file name (extension must be .txt) for the data to be downloaded into

**Date Format:** Enter in the date format that data will be written as (within the text file).  
Date must be separated by forward slashes, commas and time by colon. and must contain:

Year	yyyy
Month	MM
Day	dd
Hour	HH
Minute	mm
Second	ss

The date can be used for one of three activities

Append Data	Add data onto the end of the current entries within the text file
Overwrite Data	Always create new text file rather than adding to existing file
Prompt User	Displays a window that prompts user to overwrite data, if no is selected data will be appended to current .txt file

## Connection

The user must select the type of connection that the computer is connect to the analyzer with. This is chosen in the “**Connection Type**” field and consists of:

### Direct Serial connection:

Used when the analyzer is connected directly to PC via serial port

- Port** → Choose which port on the PC the Serinus is attached to
- Baud Rate** → Select the baud rate with which communication will take place (must match the baud rate set on the analyzer see the Serial Communications section)

### Network Connection:

Used when the analyzer is being connected via a network.

- IP Address** → Enter the IP address of the analyzer as described in Ecotech technote: TEC 0045
- Port** → Enter the port number of the analyzer as described in Ecotech technote: TEC 0045

### USB Connection:

Used when the analyzer is connected directly to PC via the USB connection

- Analysers** → A drop down list will display all analyzers that the downloader program can connect to, the user must select the appropriate analyzer number matching that of the analyzer connected to.

## Analyzer

### Analyzer ID:

Enter the analyzer ID found in the “Main Gas ID” field (Main Menu → Communications → Serial Communications)

**Note:** Only relevant for a direct serial connection

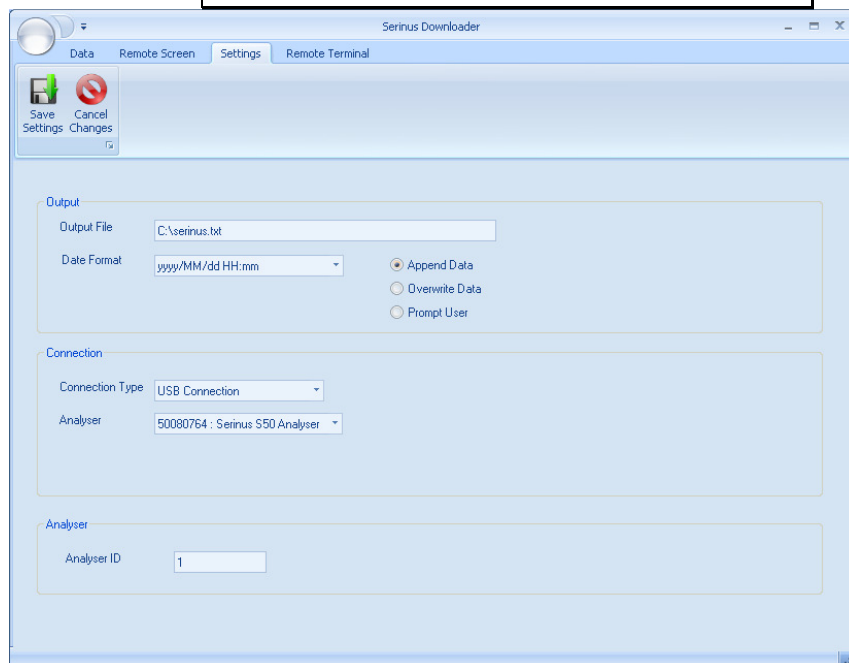

Figure 17 Serinus downloader - settings tab

## 5.5.2 Data

The Data window consists mainly of a spreadsheet with rows (numeric) and columns (labeled as per parameter). The amount of data to be uploaded into the spreadsheet is determined by the start and end date range on the left side of the main menu bar. The other features in the menu bar are:

- **Acquire data** This button acquires data from the analyzer (within the date ranges) and displays on screen along with saving as a text file
- **Save data** Saves the data into excel file format
- **Clear Data** Deletes data from the screen
- **Rebuild index** This function is used when the downloader is unable to access data. A common reason for this is a corruption or deletion of the index.dat file (on removable USB stick) or data in the text file has been deleted. Rebuilding the index will create new index files and allow all current data to be accessed.
- **Reset Memory stick** Resets the memory stick, this is used if the instrument is having problems detecting the stick.

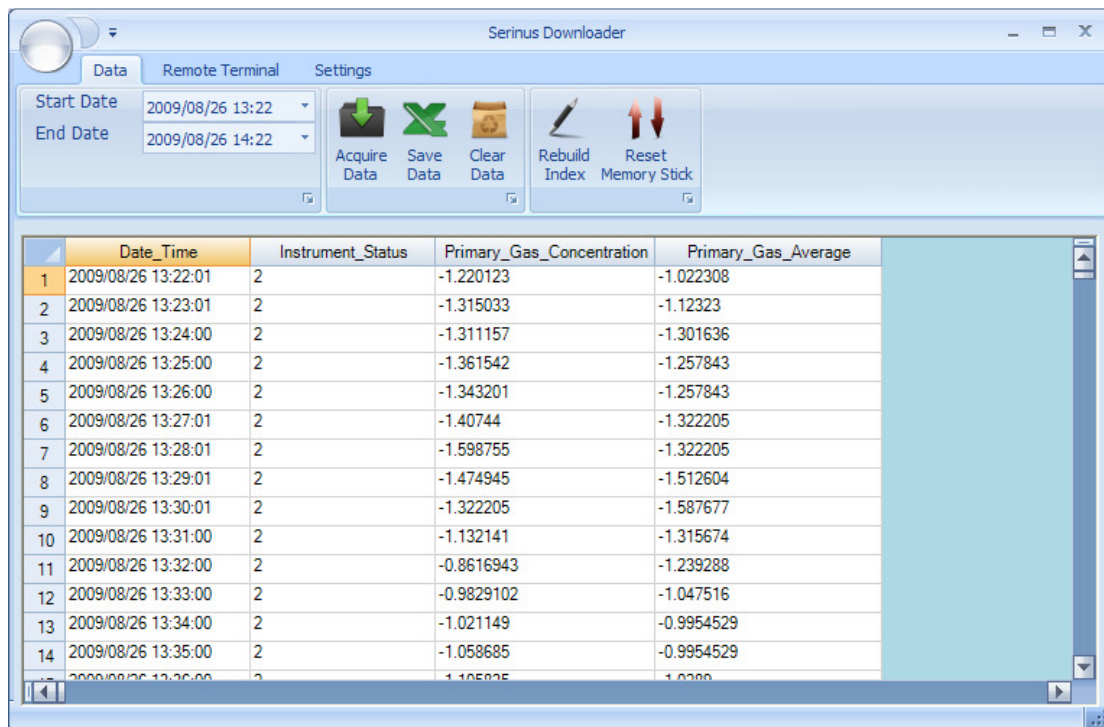

Figure 18 Serinus Downloader – Data tab

### 5.5.3 Remote screen

The remote screen tab allows the user to connect to the Serinus instrument and control it remotely. The screen has all the same buttons as the Serinus gas analyzer and is used as virtual interface with the instrument. The screen is a screenshot and not an automatically updated feed; the refresh button will need to be used when tracking changes in parameters.

- By clicking the green “Connect” button in the top left hand corner, the remote terminal session will begin.
- The session can be terminated at anytime by pressing the red “Disconnect” button
- The screen can be updated by clicking the “refresh screen” button. This must be used

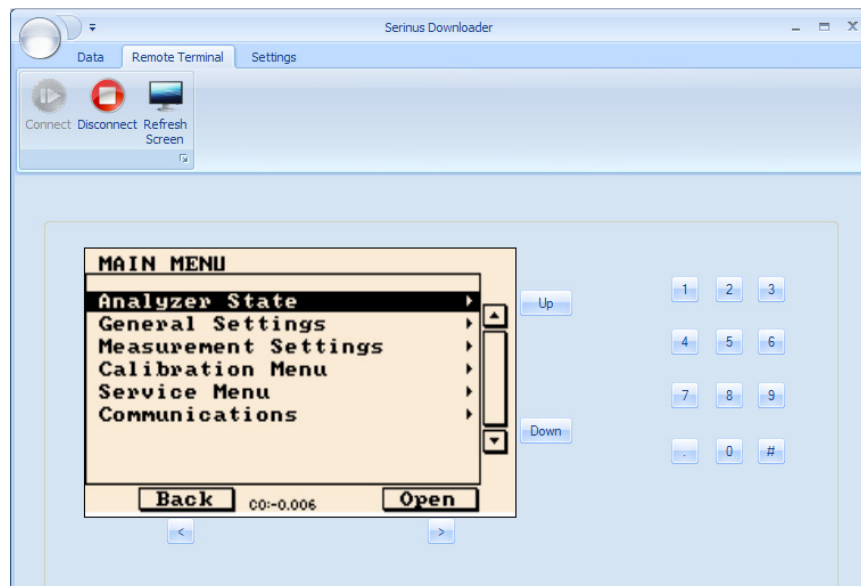

Figure 19 Serinus Downloader – Remote Screen tab

---

### 5.5.4 Remote terminal

---

The remote terminal tab is a diagnostic tool used to check instrument operation and parameters. The remote terminal is used in a similar way to “ping” a computer; it is used to ensure communications are working properly. Firstly the Downloader program must be connected to the instrument and the green connect button in the top left hand corner must be clicked. The remote terminal tab consists of 3 different sections:

- **Advanced Protocol**  
Within this section the user selects the parameter number (from within the advanced protocol) then clicks the get button to receive that parameters value
- **EC9800 Protocol**  
Within this section a command can be sent to the instrument using the EC9800 protocol. Simply type in the text command in the field and click the send button.
- **Received Data**  
This field contains the value or the parameter that has been requested. Values can be cleared by pressing the clear button

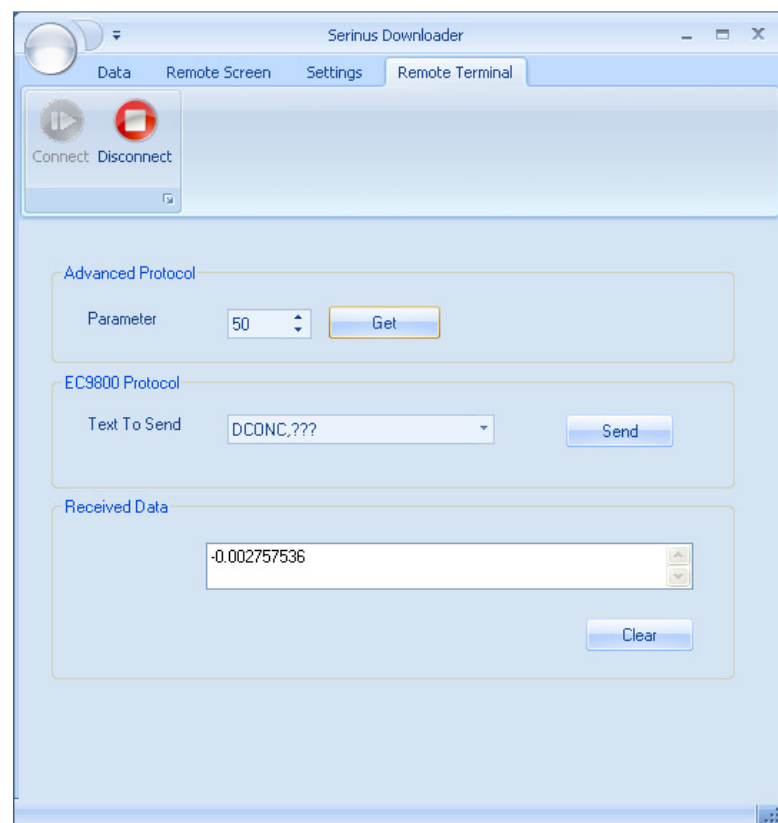

Figure 20 Serinus downloader - Remote Terminal tab

## 6 Service

### 6.1 Pneumatic diagram

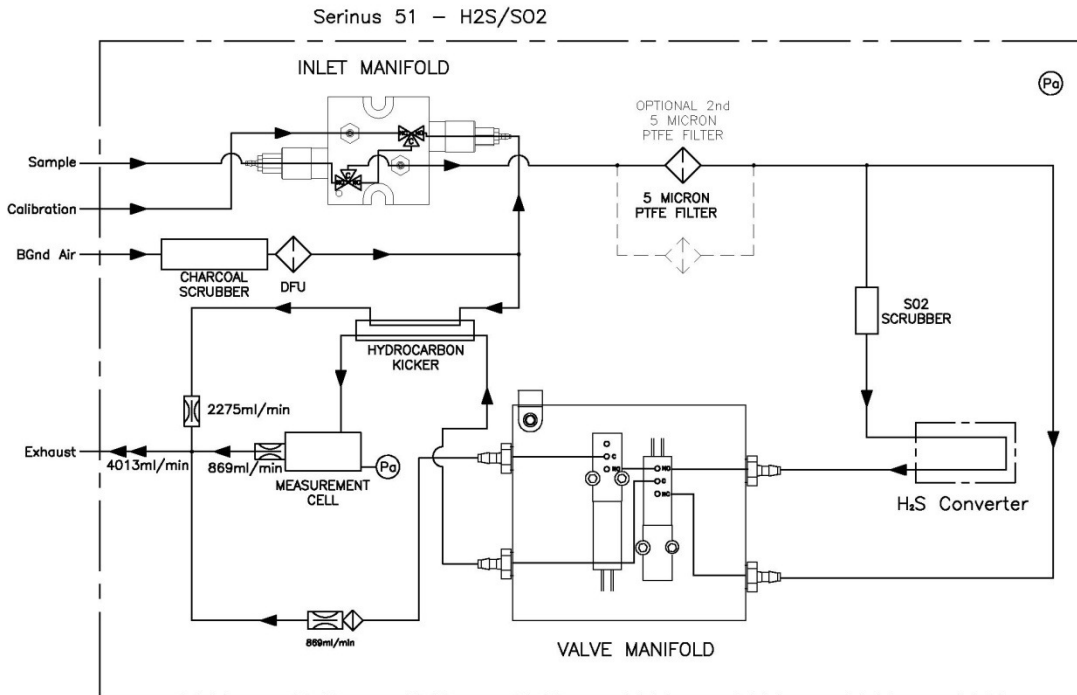

Figure 21 Pneumatic diagram

### 6.2 Maintenance tools

To perform general maintenance on the Serinus 51 the user will be require the following equipment:

- Toolbox
- Digital multimeter (DMM)
- Computer or remote data terminal and connection cable for RS232 communication
- Pressure transducer (absolute) and connection tubing, calibrated in torr
- Flow meter (1 slpm nominal)
- Minifit extraction tool
- Orifice removal tool
- 1.5mm hex key
- Assortment of 1/4" and 1/8" tubing and fittings
- Test zero air source
- Test span gas source
- Leak tester

## 6.3 Maintenance schedule

Table 1 Maintenance Schedule

Interval *	Task performed	Page
Weekly	Check inlet particulate filter, replace if full/dirty	<a href="#">55</a>
	Check sample inlet system for moisture or foreign materials. Clean if necessary	
	Perform precision check	<a href="#">40</a>
Monthly	Check fan filter, clean if necessary	<a href="#">55</a>
	Perform span calibration	<a href="#">35</a>
	Check date and time is correct	<a href="#">23</a>
6 Monthly	Check the zero air scrubber	<a href="#">58</a>
	PMT Desiccant packs	<a href="#">59</a>
	Perform multi-point calibration check	<a href="#">36</a>
Yearly	Replace DFU filter	<a href="#">56</a>
	Replace sintered filter and orifice (only if necessary)	
	Check UV lamp alignment (or as required)	<a href="#">60</a>
	Perform pressure check	<a href="#">61</a>

\* Suggested intervals for maintenance procedure may vary with sampling intensity and environmental conditions.

## 6.4 Maintenance procedures

### 6.4.1 Particulate filter replacement

1. Disconnect the external pump
2. Slide open (Figure 22) to access the particulate filter (located in front right hand corner)
3. Unscrew the filter cap (bright blue) by turning it counterclockwise
4. Remove the filter plunger from the casing, place finger on tubing connector and pull to the side

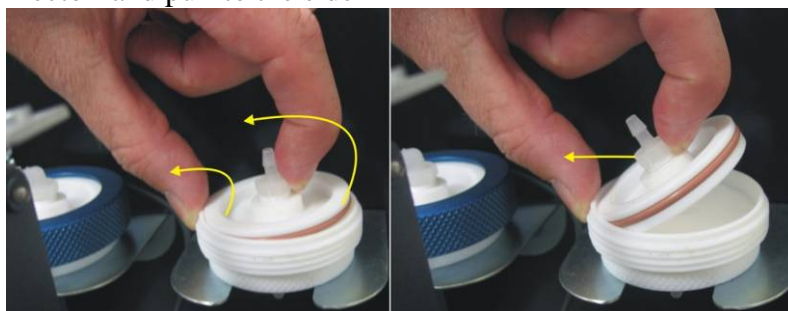

Figure 22 Removing plunger

5. Remove old filter, wipe down plunger with damp cloth and insert new filter
6. Replace plunger, screw cap on and reconnect the pump
7. Close instrument and perform a quick leak check (section 6.4.5)
8. Resume monitoring

### 6.4.2 Clean fan Filter

1. Turn off fan
2. Remove outer filter casing and filter (Figure 23)
3. Clean filter by blowing with compressed air (if available) or shaking vigorously
4. Replace filter and filter casing



Figure 23 Removing fan filter

---

### 6.4.3 DFU Replacement

---

1. Turn off analyzer and remove power
2. Remove Kynar nut from the end of the DFU by turning anti-clockwise (looking from DFU side)
3. Replace DFU and ensure that the flow is in the correct direction (arrows points toward Kynar nut)
4. Tighten kynar nut clockwise

---

### 6.4.4 Sintered filter Replacement

---

The sintered filter is used to prevent contaminants blocking the sample orifice. Sintered filters should be changed per year

1. Turn off the analyzer and disconnect the pump
2. Disconnect the tubing from the T-piece on top of the measurement cell (Figure 24)

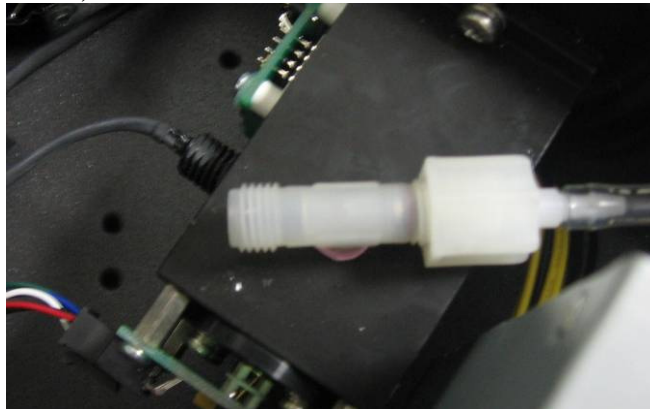

**Figure 24 Measurement cell T-piece**

3. Unscrew the T-piece from the cell (anti-clockwise)
4. Once the t-piece has been removed use the orifice/filter removal tool to remove either the orifice and/or filter
5. Orifice and filter maybe exchanged with new ones or cleaned as needed.
6. Replace the filter and/or orifice in the correct part of the T-piece and replace the T-piece as before.
7. Perform a calibration

---

### 6.4.5 Quick Leak test

---

This procedure is designed to determine if the instrument pneumatics has a leak, this initial check. If the instrument passes the check then no further leak checks are needed, if it fails a full leak check will be required.

1. Enter main menu → Diagnostics → Valve menu and set valve sequencing to off. Then open all the valves in that menu
2. Plug both the “Sample port” and the “Calibration port” (see Figure 25 below)

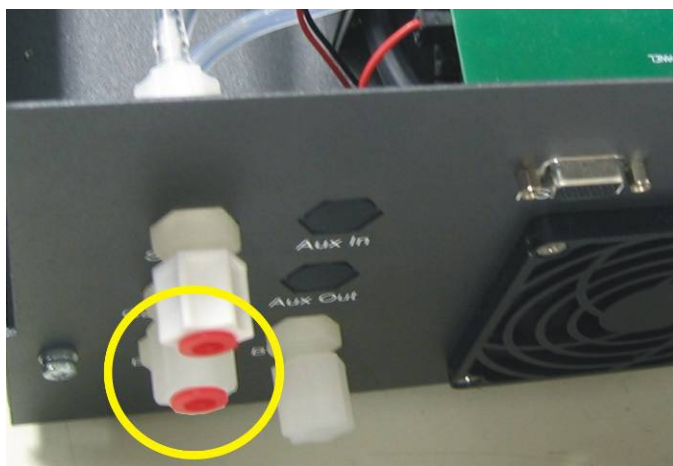

**Figure 25 Plugged sample and calibration ports**

3. Enter the main menu → status menu → pressure menu and compare the ambient pressure to the inst gas pressure
4. Allow 1-2 minutes for the pressures to stabilize, check that the gas flow = 0, if this is not the case then there is a leak
5. If the two pressures are within 10% of each other then the leak check has passed.
6. If the pressures fluctuate with channel switching or are more than 10% different, perform pressure calibration (section 4.5), after this is completed repeat quick leak check, if this again fails perform advanced leak check (section 6.4.6).

### 6.4.6 Advanced leak check

If a leak is suspected a more intensive leak check can be performed.

1. Continue from the setup in the quick leak check.
2. Connect a pump to the exhaust port with a shut off valve (pump side) and a vacuum gauge (exhaust port side) between the two
3. Ensure that the shut off valve is open then turn on the pump (1-2 minutes) and create a vacuum.
4. Close the shut off valve and measure the vacuum. If the vacuum slowly drops (pressure rises) then a leak is present
5. Open each valve individually, leaving the other two closed, and using the plumbing diagram determine the location of the leak
6. When the location of the leak has been determined check all tubing and fittings to make sure that they are attached appropriately and have no splits or cracks

### 6.4.7 Replace Zero air scrubber

1. Open the lid of the analyzer
2. Remove the tubing from the barb fitting on top of the scrubber (1 in Figure 26)
3. Remove the DFU from the fitting below the scrubber by pulling it out (2 in Figure 26)
4. Now the scrubber holder can be opened with a screwdriver (3 in Figure 26)

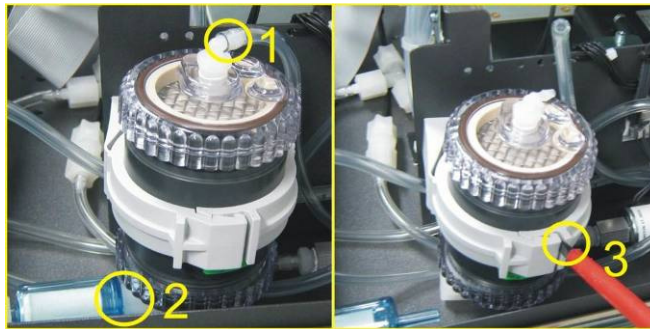

**Figure 26 Zero scrubber removal**

5. The zero scrubber can now be replaced with a new scrubber and all fittings and tubing replaced
6. Perform a leak check (section 6.4.5)
7. Perform a zero and span calibration (section 4.1 and 4.2)

Average SO <sub>2</sub> Concentration	Charcoal Replacement
0 to 30 ppb	12 Months
30 to 100 ppb	6 Months
> 100 ppb	1 Month

### 6.4.8 Replace PMT desiccant pack

The PMT housing contains two desiccant packs to prevent condensation on the cooled PMT housing. If the desiccant expires it will result in corrosion of the PMT housing and premature cooler failure. It is recommended that the desiccant bags be changed at least annually. If moisture is detected inside the housing or the desiccant packs are saturated the interval should be reduced. To change the desiccant packs perform the following:

#### Caution

Because the PMT is extremely sensitive to light, it is essential that before opening the PMT assembly to make sure that the analyzer is switched off. In addition, even when the analyzer is switched off it is very important to cover the PMT at all times so that no direct light reaches its window.

1. Turn the analyzer off and disconnect power.
2. Using an offset Phillips head screwdriver, remove the desiccant pack access cap from the PMT housing.

#### Note

Removal of the desiccant access cap may be easier if the Rx cell/PMT housing is removed from the analyzer. Refer to section 3.3.8.

3. Remove the old desiccant packs and replace with new (see Figure 27). Do not attempt to dry and reuse the old packs.

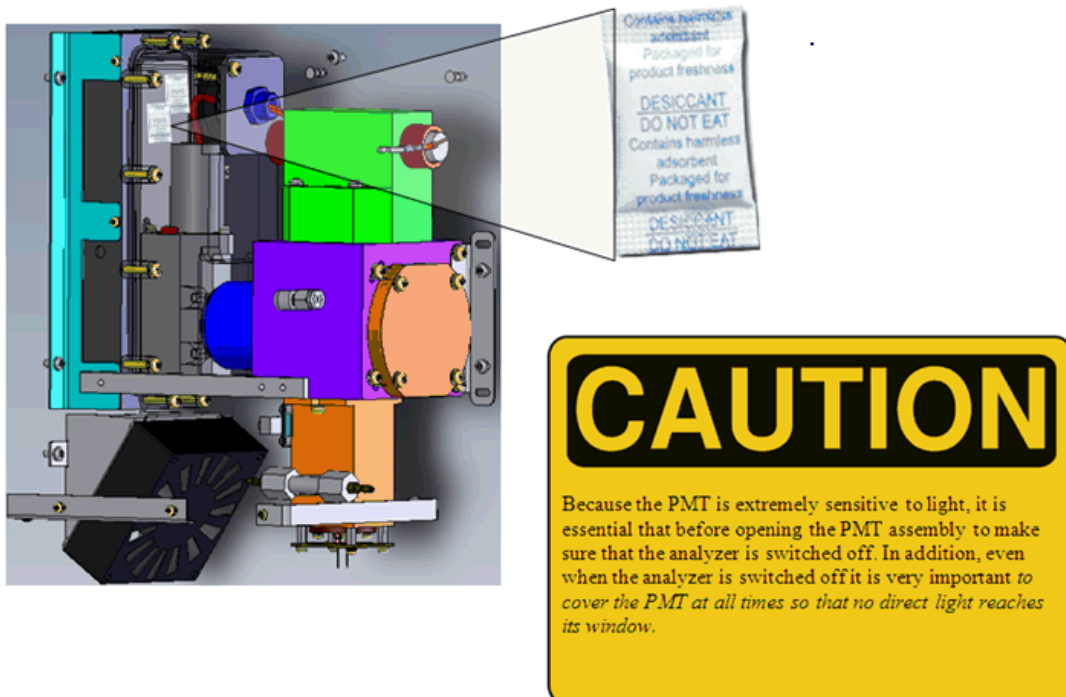

Figure 27 Position of desiccant packs

4. Inspect the inside of the PMT housing (by touch or with an inspection mirror) to check for moisture inside the housing. If moisture is detected inside the housing, the desiccant pack replacement frequency should be increased.
5. Reinstall the desiccant cap by gently twisting and pressing the cap back into the PMT housing. It may help to apply a small amount of lubricant to the O ring on the desiccant cap. Secure with two screws.

**Caution**

Do not attempt to insert the desiccant cap into the PMT housing by using the screws to pull the cap into place. This will damage the PMT housing.

6. Reconnect power and restart the analyzer.

---

#### 6.4.9 Replace DFU filter

---

1. Turn off analyzer and remove power
2. Remove DFU from kynar nut by pulling and twisting slightly if any resistance.
3. Remove tubing connected to the DFU on the other side
4. Replace DFU and ensure that the flow is in the correct direction (arrows points toward tubing)

---

#### 6.4.10 Check UV lamp alignment

---

Required equipment:  
Oscilloscope

Proper operation of the UV lamp is essential to the Serinus 51. The UV lamp should be checked yearly to ensure it is operating within acceptable parameters and may require realignment to maintain sufficient UV light for analyzer operation. The UV lamp will need to be adjusted only when the “Reference gain pot” goes above 200 or below 5. Following are procedures to check, align, and replace the UV lamp assembly.

**Warning**

The Lamp Driver PCA can generate in excess of 1000 volts. Exercise extreme care when working in the vicinity of the Lamp Driver.

**Caution**

If the UV lamp is adjusted, the analyzer will require recalibration.

1. Turn the analyzer on and allow the UV lamp to warm up and stabilize (about 30 minutes).
2. Connect an oscilloscope to TP19 (SO<sub>2</sub> REFX2) on the Main controller board and TP1 (AGND). Adjust the scope for 0.5 V/division and 20 msec/division.
3. Loosen the collets (do not remove) at each end of the lamp (Figure 28).



**Figure 28 Collets of the UV lamp**

4. Physically adjust the UV lamp (rotate and move left and right) until the maximum peak voltage on the oscilloscope is obtained. The minimum usable output from the lamp is approximately 0.25 volts amplitude (peak to peak). If the UV lamp output is below 0.5 volts, then replacement should be considered.
5. Tighten the UV lamp collets and verify the UV lamp has remained at its previously adjusted position.
6. Reset the analyzer and allow it to run a startup sequence.
7. Instrument must now be recalibrated

---

#### **6.4.11 Pressure sensor check**

---

Flow checks are needed to ensure that the pressure sensor is accurately measuring pressure inside the instrument

1. Remove the exhaust and sample tubing from the back of the analyzer
2. After 5-10 minutes observe the pressure reading in the “cell” (section 3.5.2.3)
3. Compare the Serinus pressure sensor measurement to the current ambient pressure from an external calibrated sensor. Ensure that they are reading the same  $\pm 3$  TORR ( $\pm 0.4$  kPa)
4. If no external pressure sensor is available, compare the serinus “cell” pressure to the “ambient” pressure (section 3.5.2.3). Ensure that they are reading the same  $\pm 3$  TORR ( $\pm 0.4$  kPa)
5. If the readings are outside this level then perform a Pressure calibration (section 4.5)

---

#### **6.4.12 Battery Replacement**

---

The replaceable battery (BT1) on the main controller board may need to be replaced should it go flat. If the clock settings reset or do not increment when the power is off, then this is a good indication that the battery is going flat. The battery should be replaced with the correct type of battery, a 3V Lithium CR2025 type should be used and installed correctly as follows:

1. Turn off the Instrument, open the cover and remove the 2 screws holding down the main controller PCB.
2. Lift the PCB up to its Open position. The battery (BT1) is located toward the front of the PCB.

3. Using a small flat screwdriver, lift the metallic clip holding the battery whilst sliding the old battery out.
4. Now place the new battery in with the positive (+) side facing up.
5. Close the main PCB and return the screws. Close the cover again.
6. Turn on the instrument and set the clock time and date in the main menu – General Settings.

## 6.5 Parts list

Below is a list of the replaceable parts of the Serinus 51. Some of these parts will not need replacing and other consumables will need constant replacing.

Table 2 Parts List

Part Description	Part Number
<b>Spare parts</b>	
Scrubber assembly charcoal for Zero/Air, Serinus	H010038
Filter Glass, U340	H012114
Filter, Ultraviolet	H012116
Photomultiplier tube	H012132
LCD and interface assembly	D010001
PCA, Controller	C010001
Power Supply, Serinus	P010003
PCA, lamp driver	C010006
PCA, reference detector	C010008
Sample valve manifold assy Serinus	H010013-01
Cooler thermoelectric	H011202
Thermistor assembly	S030006
Charcoal activated, 1kg bottle	A-ECO-1035
Lense plano convex	H012117
Kicker assembly (hydrocarbon scrubber)	H012140
Heater and thermistor assembly	C020074
Power supply optical bench	H011211-02
Cooler, thermoelectric kit	H011211-03
Thermistor assembly kit	H011211-04
Serinus 51 User Manual	M010040
Lense Biconvex	H012118
Filter element, 5 micron, consumable (50 each)	F010006-01
Scrubber assembly charcoal for zero/air, Serinus	H010038
Gasket Pressure Sensor	H010037
<b>Serinus 50 Maintenance Kit (includes consumables below)</b>	<b>E020204</b>
O-ring 0.364ID X 0.070W	O010010
O-ring, plano convex lense	O010027
O-ring, Dump-Cell Assembly	O010028
O-ring, U340	O010029
Silicone Heatsink Compound	C050013
Filter unit disposable	F010005
O-ring, Dessicant cap	O010022
O-ring Reaction cell to optical bench	O010017
O-ring 1/4ID X 1/16W, viton	O010015
O-ring 13/16ID X 1/16W, viton	O010016
O-ring, Ultraviolet filter	O010026
Washer shoulder Nylon M3 x 6	F050040
O-ring 5/32ID X 1/16W, viton (3 required)	O010013
O-ring, Photo detector	O010031
O-ring 1 11/16ID X 3/32W viton (2 required)	O010014
O-ring, Opt Bench	O010018

Dessicant, 5 gram pack (2 required)	C050014
O-ring, Test Plug, Test lamp	O010021
Fitting kynar male branch tee	F030033-01
Washer neo, .174x .38x.016	F050041
O-ring BS115, viton	O010004
O-ring BS015, viton (3 required)	O010023
O-ring, reaction cell cover plate	ORI-1019
Tygon tubing (3ft)	T010011
<b>Other consumables (not listed in maintenance kit)</b>	
Filter paper Teflon 47MM pack of 50	F010006-01
Filter paper Teflon 47MM pack of 100	F010006-01
Charcoal activated, 1KG bottle	A-ECO-1035
Orifice, 14 mil	H010043-13
Orifice, 20 mil	H010043-19
Lamp Assembly, UV	C020076
External pump repair kit (suite 607 pump)	P031001
Silicone heatsink compound	C050013
SO2 Scrubber	H040011-01
Molycon Assembly, Serinus, H2S	H011105-03
Bypass Orifice W/O-Ring Groove, 12ML	H010043-11

## 6.6 Updating firmware

### USB memory stick update

1. Turn instrument off
2. Place USB memory stick with new firmware on the Front panel USB port
3. Turn instrument on and immediately press the hash key multiple times until the following screen appears

Vx.x Bootloader Press '1' to enter Bootloader
--

4. Select option 3, (Upgrade from USB memory stick) press 3 on keypad
5. Once update is completed.
6. Press 9 to start the analyzer with new firmware

## 7 Troubleshooting

Table 3 Troubleshoot list

Error Message/ Problem	Cause	Solution
A/D conversion error	Temp/press error	Replace main PCB
Input pot limited to 0 or 255	Damaged Lamp	Check that lamp current is between 21 & 35mA. If not replace Lamp driver board. If pot still 255, replace UV lamp
Zero Flow	Multiple	Troubleshoot 7.1
Reset Detection		Upgrade firmware
Electronic zero adjust	Faulty zero air or pneumatics	Troubleshoot 7.2
12 Voltage supply failure	Power supply has failed	Replace power supply
Cell temperature failure		Troubleshoot 7.3
No display	AC power	<ol style="list-style-type: none"> <li>1. Verify that the line cord is connected.</li> <li>2. Check that the power supply fuse is not open. The fuse should be 5A (115 V) or 3A (230 V).</li> <li>3. Verify that the voltage switch is in the proper position.</li> </ol>
	Contrast misadjusted	Set or adjust the display contrast by simultaneously pressing two keys on the front panel as follows: - Contrast: Press Up arrow (▲) for darker contrast, Down arrow (▼) and <Select> for lighter contrast.
	DC power	Verify that the power supply is providing $\pm 12V + 5V$ DC
	Display	Check the interface cable between the display and the microprocessor board.
	Bad display or Microprocessor PCA	<ol style="list-style-type: none"> <li>1. Replace the front panel display.</li> <li>2. Replace the microprocessor board.</li> <li>3. A bad cable is unlikely, but if you suspect it, perform a pin-for-pin continuity test using an ohmmeter.</li> </ol>
Noisy or unstable readings	Leaks	A leak dilutes the sample stream and causes low span readings and noise.
	Lamp not correctly positioned	Adjust the UV lamp. If you are unable to obtain an acceptable reading, replace the lamp.
	TE cooler or Reaction cell heater	A failed temperature control allows the instrument zero to drift with ambient

		temperature. Verify that the cell temperature is $50^{\circ} \pm 3^{\circ} \text{ C}$ and that the TE cooler is $10^{\circ} \pm 2^{\circ} \text{ C}$ .
Low span	Leaks	A leak dilutes the sample stream and causes low span readings and noise.
	Span calibration out	Adjust the span using the calibration procedure
	Faulty lamp	Replace UV Lamp
No response to span gas	Leaks/blockages	Leak or blockages in tubes or valves. Perform leak check and flow check and repair any leaks/blockages.
	Faulty calibration source	Ensure calibration gas is plumbed correctly, is not contaminated and is a NATA/NIST reference gas.
Zero drift	No flow	Check sampler flow
	Charcoal saturated	Replace the charcoal.
	Faulty zero air	Ensure zero air source is not overly polluted
Unstable flow or pressure readings	Faulty pressure sensors	Replace main PCB

## 7.1 Zero Flow

**Table 4 Zero flow Troubleshoot**

Cause	Solution
Pump failed	Replace the internal or external pump.
Blocked filter or orifice	Replace sintered filter and orifice
Pressurized Rx cell	Ensure Sample and Zero inlets are maintained at ambient pressure.
Flow control assembly	Recalibrate the flow control assembly.

### 7.2 Electronic Zero adjust

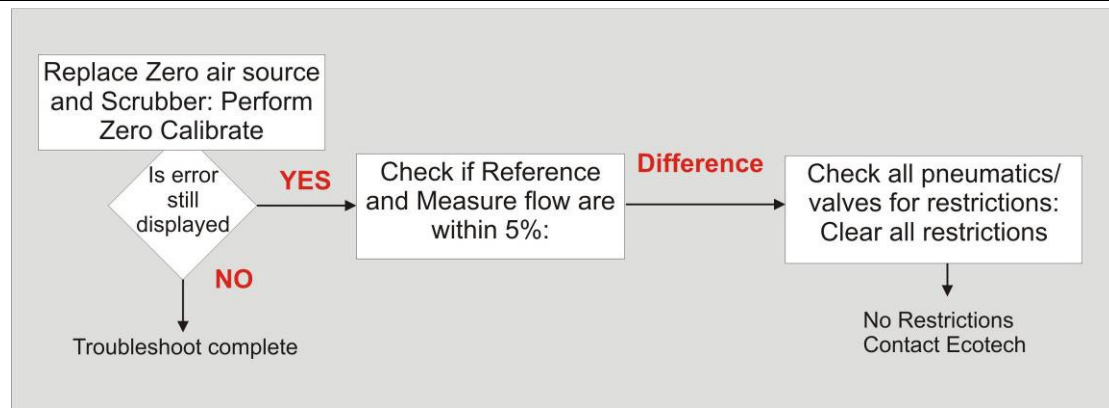

### 7.3 SO<sub>2</sub> reaction cell temperature failure

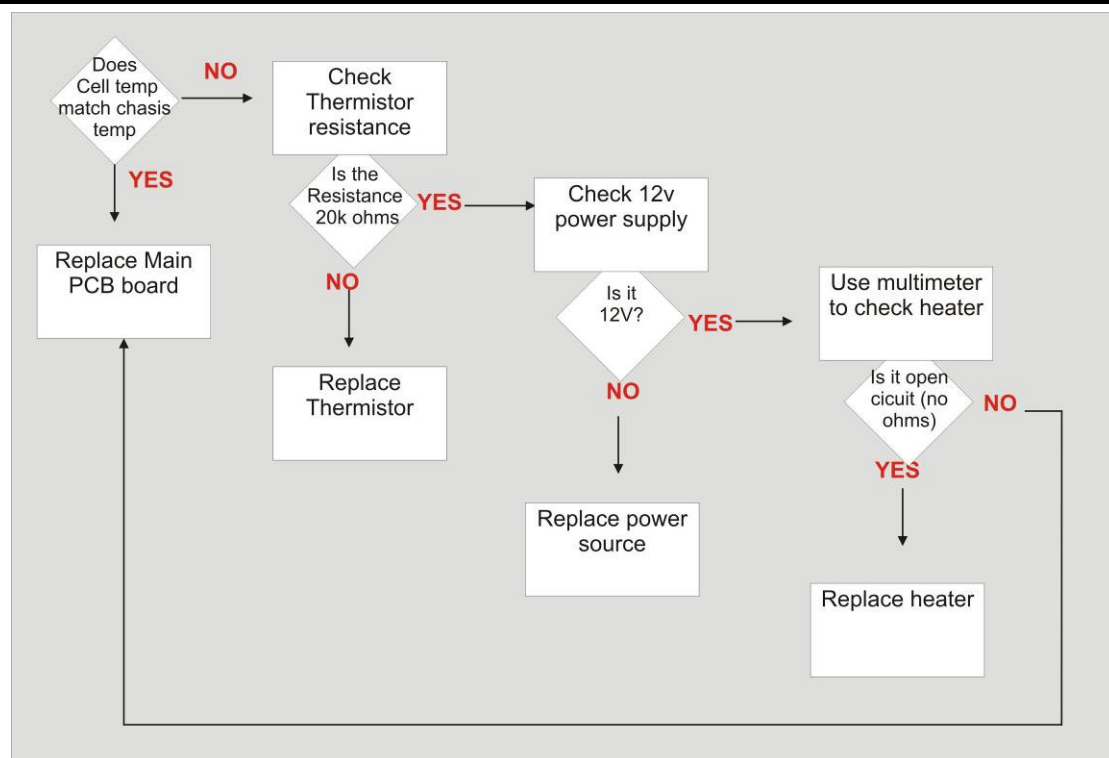



## 8 Optional Extras

### 8.1 Dual sample filter

The dual filter is designed with two sample filters plumbed in parallel with a split line. This formation allows sample flow not to be affected, yet reduces the loading on each filter, and therefore the frequency with which they will need to be changed. The dual filter option is shown in the pneumatic diagram (red dashed line) and requires no operational changes to the instrument.

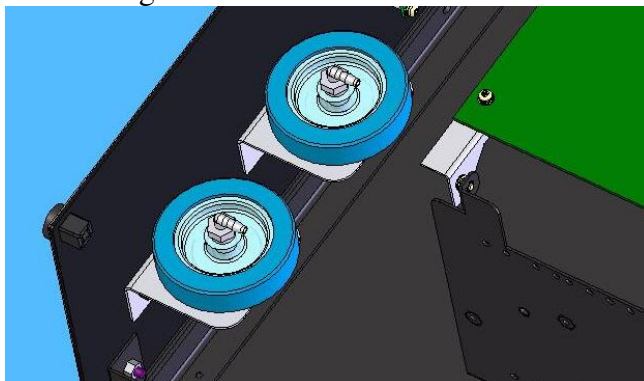

Figure 29 Dual filter option installed

### 8.2 Rack mount kit

The rack mount kit is necessary for installing the Serinus 51 into a 19" rack. The Serinus 51 is 4RU in height to install in the rack follow these steps.

#### Installing the instrument

1. Remove the rubber feet from the analyzer (if attached)
2. Install the two H shaped instrument brackets onto the left and right side of the rack securely with M6 bolts (two at the back and two at the front) shown circled in Figure 30.



Figure 30 Installation of rack mount brackets

3. Insert the instrument lid (without the instrument) into the rack and attach to the already installed instrument brackets with M6 bolts, shown circled in Figure 31.

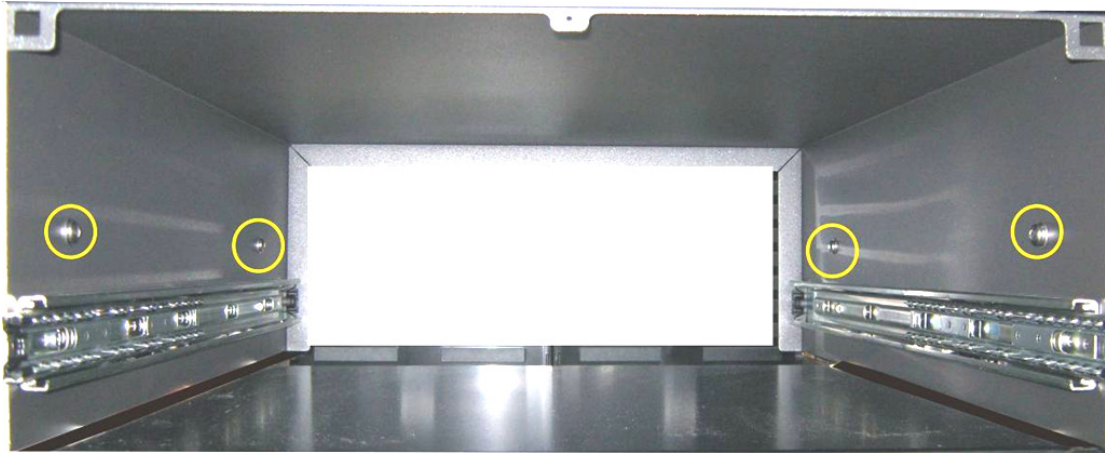

**Figure 31 Installation of lid to rack mount brackets**

4. Check that the instrument lid is not bowed (bent), if there is a bow adjust bracket and lid bolts until the lid is square, and bolts are tight.
5. Now carefully insert the instrument into the rack by placing the instrument slides into the lid slides, ensure that the rack slide locks engage (Figure 32) on each side (you will hear a click) and gently slide the instrument into the rack.

**Note:** Ensure both sides of the slide are attached to the lid slides before pushing into rack

### Removing the instrument

1. To remove the instrument first pull instrument out of rack giving access to the slides
2. Find the rack slide lock labelled “push” (Figure 32) and push it in whilst sliding the instrument out of the rack, complete this for both sides before carefully removing instrument

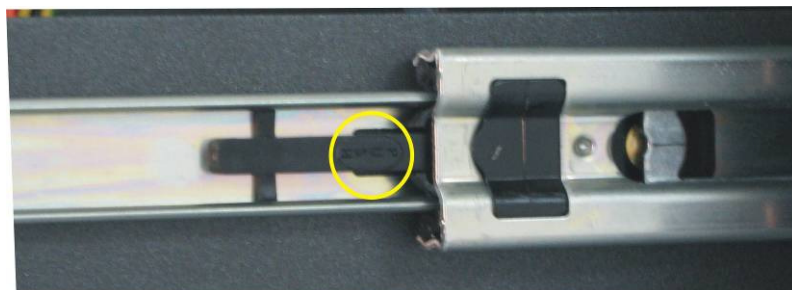

**Figure 32 Rack slide lock**

3. Unscrew lid by removing M6 bolts shown in Figure 31
4. Slide lid back on to instrument ready for transport or storage

## 8.3 High pressure zero/span valve

**Note:** This is NOT intended as a source for calibrating the instrument. This should only be used as an operational check of the instrument's zero point and single upscale point (recommended as 80% of full scale)

### 8.3.1 Single pressurized calibration option

The internal pressurized calibration valves are already installed within the analyzer (Figure 33) as either a zero or span calibration source, thus no other connections need to be made.

#### Operation of single calibration option

When using the pressurized calibration option either a high pressure zero or span bottle should be connected to the "Auxiliary In" port on the back of the analyzer.

1. Ensure gas cylinder is fitted with an appropriate gas regulator with shut off valve.
2. Connect a line of 1/8" stainless steel tubing between the gas cylinder and the analyzer "Auxiliary port" inlet.

**Note:** This connection may need to be retightened during this operation.

3. Open the cylinder main valve and adjust the regulator to 15 psig or 1 bar
4. Open the regulator shutoff valve and leak test.
5. Temporarily place a flow meter on the calibration port inlet (used as a vent).
6. Enter the calibration menu (Main Menu → Calibration Menu)
7. Change "Set Cal Port" to External
8. Select either Span or Zero under the "Cal Mode" option depending on which calibration check is being performed. This will initiate the pressurized calibration.
9. Open the cylinder shutoff valve, adjust the regulator pressure until the flow on the vent line (Calibration port) is between 0.5 and 1 lpm.

**Note:** Do not exceed 2 bar of pressure, if this occurs a leak may exist

#### Return to normal operation

1. Set Cal. Mode → Measure.
2. Remove the flow meter on the calibration port and connect a 1/4" vent line to port.
3. Reconnect instrument fittings and place in original set up
4. The instrument is now in normal operation mode.

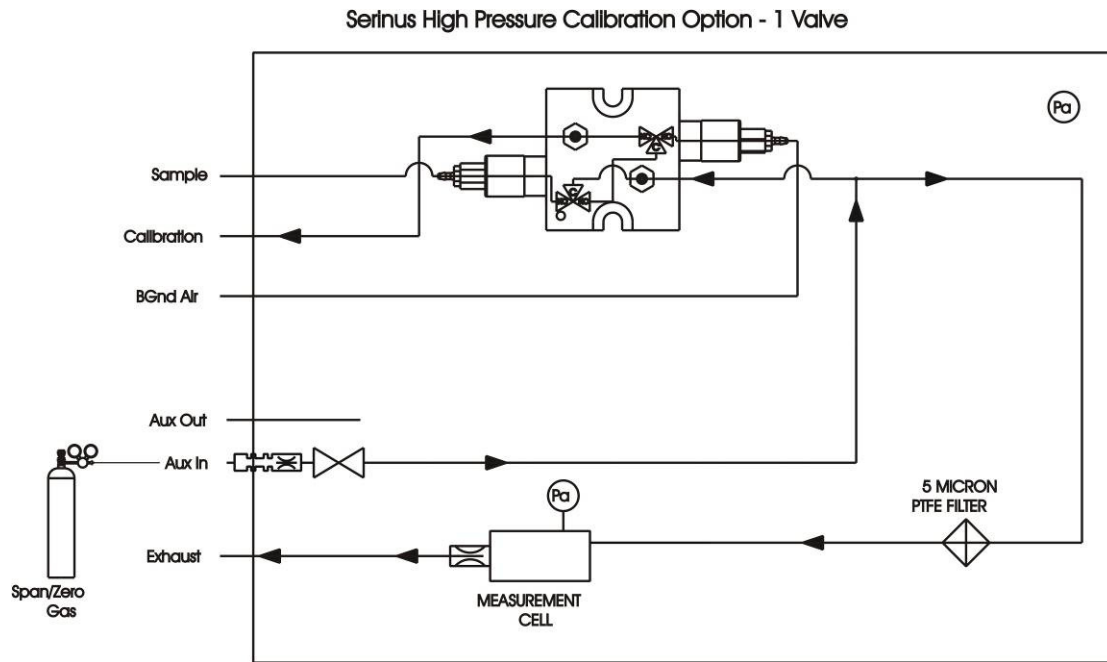

**Figure 33 Single high pressure calibration option**

### 8.3.2 Dual pressurized calibration option

The dual internal pressurized calibration valves are already installed within the analyzer (Figure 34) as a zero and span calibration source, thus no other connections need to be made.

#### Operation of dual calibration option

When using the pressurized calibration option a high pressure zero bottle should be connected to the “Auxiliary In” port and a high pressure span bottle connected to the “Calibration” port on the back of the analyzer.

1. Ensure gas cylinder is fitted with an appropriate gas regulator with shut off valve.
  2. Connect a line of 1/8” stainless steel tubing between the appropriate gas cylinder and the analyzer inlet port.
- Note:** This connection may need to be retightened during this operation.
3. Open the Main Valve and adjust the regulator to 15 psig or 1 bar
  4. Open the regulator shutoff valve and leak test.
  5. Temporarily place a flow meter on the “Auxiliary Out” port (used as a vent).
  6. Change “Set Cal Port” to External (Main Menu → Calibration Menu) then select either span or zero under the “Cal Mode” option depending on which calibration check is being performed. This will initiate the pressurized calibration.
  7. Open the cylinder shutoff valve; adjust the regulator pressure until the flow on the vent line (Calibration port) is between 0.5 and 1 lpm.

**Note:** Do not exceed 2 bar of pressure, if this occurs a leak may exist

### Return to normal operation

1. Set Cal. Mode → Measure.
2. Remove the flow meter on the calibration port and connect a ¼” vent line to port.
3. Reconnect instrument fittings and place in original set up
4. The instrument is now in normal operation mode.

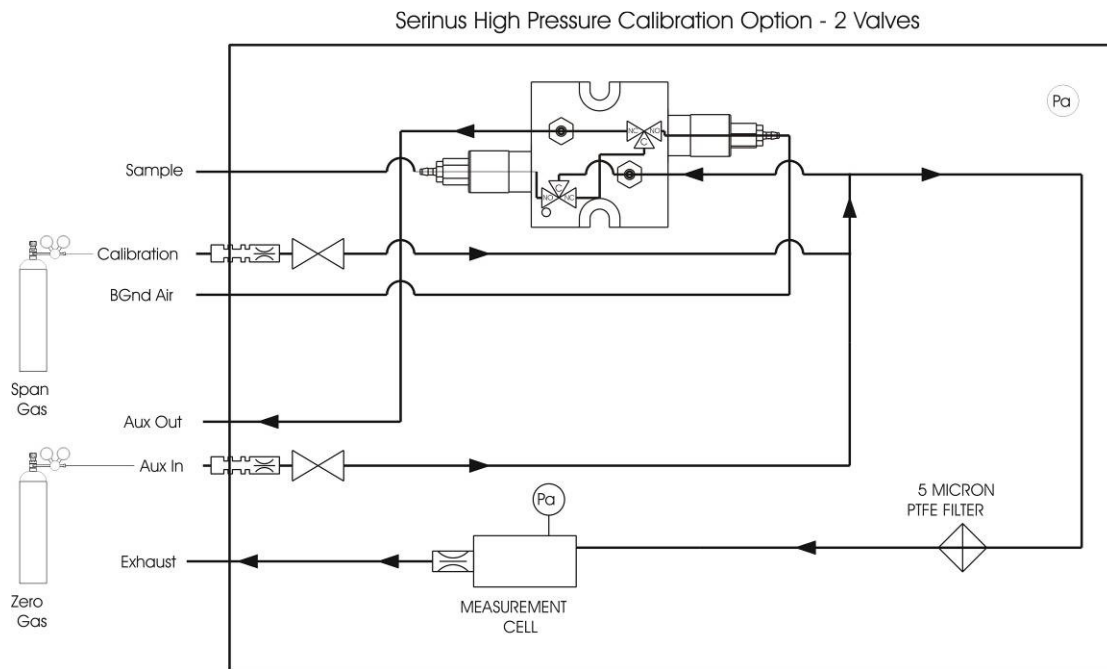

**Figure 34 Dual high pressure calibration option**



## Appendix A Advanced Protocol Parameter List

**Note:** Parameters are for all Serinus analyzers and may not be applicable to an individual analyzer.

**Table 5 Advanced Protocol Parameter list**

#	Description	Notes
0	Sample / Cal Valve	0=Sample, 1=Cal/Zero
1	Cal / Zero Valve	0=Zero, 1=Cal
2	Internal Span Valve	0=Closed, 1=Open
3	Spare Valve 1	0=Closed, 1=Open
4	Spare Valve 2	0=Closed, 1=Open
5	Spare Valve 3	0=Closed, 1=Open
6	Spare Valve 4	0=Closed, 1=Open
7	NOx Measure Valve	0=NO, 1=NOx
8	NOx Bypass Valve	0=NO, 1=NOx
9	NOx Background Valve	0=Closed, 1=Open
10	Valve Sequencing	0=Off, 1=On
11	LCD Contrast Pot	0=Lightest, 255=Darkest
12	SO2 REFERENCE ZERO Gain Pot	S50 Reference ZERO POT
13	CO Measure Gain Pot	S30 Measure Gain Adjust
14	CO Reference Gain Pot	
15	CO Test Measure Pot	SEE 149. EXISTS
16	& PMT HIGH VOLTAGE Pot	High Voltage Controller Pot for PMT S50 & S40
17	SO2 Lamp ADJ Pot	S50 Lamp Adjust Pot
18	O3 Lamp ADJ Pot	S10 Lamp Adjust Pot
19	O3 ZERO Measure Pot: Coarse	S10 Signal Zero (coarse)
20	O3 ZERO Measure Pot: Fine	S10 Signal Zero (fine)
21	PMT Fan Pot	PMT fan speed controller Pot
22	Rear Fan Pot	CHASSIS Fan speed control POT
23	PUMP SPEED Motor Driver Pot: Fine	INTERNAL Pump speed fine POT
24	PUMP SPEED Motor Driver Pot: Coarse	INTERNAL Pump speed coarse POT
25	Analogue input 0	SO2 REFERENCE SIGNAL
26	Analogue input 1	CO REFERENCE SIGNAL
27	Analogue input 2	O3 REFERENCE SIGNAL
28	Analogue input 3	SO2 & O3 LAMP CURRENT
29	Analogue input 4	FLOW BLOCK PRESSURE
30	Analogue input 5	CELL PRESSURE
31	Analogue input 6	AMBIENT PRESSURE
32	Analogue input 7	RAW ADC CALIBRATION INPUT
33	Analogue input 8	MFC1 NOT USED
34	Analogue input 9	CONCENTRATION DATA
35	Analogue input 10	MFC2 NOT USED
36	Analogue input 11	MFC3 NOT USED
37	Analogue input 12	EXTERNAL ANALOG INPUT 0
38	Analogue input 13	EXTERNAL ANALOG INPUT 1

39	Analogue input 14	EXTERNAL ANALOG INPUT 1
40	Analogue input 15	MFC0 NOT USED
41	CO Measure Pot : Coarse	S30 Measure ZERO Coarse adjustment Pot
42	CO Measure Pot: Fine	S30 Measure ZERO Fine adjustment Pot
43	SO2 Measure SIGNAL Gain Pot	SO2 Measure Signal Gain Pot
44	SO2 REFERENCE Gain Pot	SO2 Reference Signal Gain Pot
45	SO2 SIGNAL ZERO	SO2 Measure Zero Pot
46	O3 SIGNAL GAIN POT	O3 INPUT SIGNAL GAIN POT
47	Test Pot	Test Pot for all the analysers
48	NOX Signal GAIN Pot	PMT signal input gain control FOR NOX
49	PGA Gain	1, 2, 4, 8, 16, 32, 64, 128
50	Primary Gas Concentration	Current value on front screen
51	Secondary Gas Concentration	Current value on front screen(if applicable eg NOx)
52	Calculated Gas Concentration	Gas 3 (eg:NO2)
53	Primary Gas Average	Average of the readings(for Gas1) of the last n minutes where n is the averaging period
54	Secondary Gas Average	
55	Calculated Gas Average	
56	Instrument Gain	
57	Main Gas ID	
58	Aux Gas ID	
59	Decimal Places	
60	Noise	
61	Gas 1 Offset	
62	Gas 3 Offset	
63	Flow Temperature	
64	Lamp Current	
65	Digital Supply Voltage	Digital Supply voltage (should always read close to 5 volts)
66	Concentration Voltage	
67	PMT High Voltage	High Voltage reading for PMT
68	Ozonator Status	0=Off, 1=On
69	Control Loop	
70	Diagnostic Mode	
71	Gas Flow	
72	Gas Pressure	
73	Ambient Pressure	
74	12V Supply Voltage	The 12 volt Power supply voltage
75	Cell Temperature	
76	Converter Temperature	
77	Chassis Temperature	
78	Manifold Temperature	
79	Cooler Temperature	
80	Mirror Temperature	
81	Lamp Temperature	
82	O3 Lamp Temperature	
83	Instrument Status	

84	Reference Voltage	
85	Calibration State	0 = MEASURE 1 = CYCLE 2 = ZERO 3 = SPAN
86	Primary Raw Concentration	(before NOx background and gain)
87	Secondary Raw Concentration	(before NOx background and gain)
88	NOx Background Concentration	(before gain)
89	Calibration Pressure	
90	Converter Efficiency	
91	Multidrop Baud Rate	
92	Analog Range Gas 1	
93	Analog Range Gas 2	
94	Analog Range Gas 3	
95	Output Type Gas 1	1=Voltage 0=Current
96	Output Type Gas 2	1=Voltage 0=Current
97	Output Type Gas 3	1=Voltage 0=Current
98	Voltage Offset /Current Range Gas1	0=0% or 0-20mA 1=5% or 2-20mA 2=10% or 4-20mA
99	Voltage Offset /Current Range Gas2	0=0% or 0-20mA 1=5% or 2-20mA 2=10% or 4-20mA
100	Voltage Offset /Current Range Gas3	0=0% or 0-20mA 1=5% or 2-20mA 2=10% or 4-20mA
101	Full Scale Gas 1	5.0 Volt Calibration value for Analog Output 1
102	Full Scale Gas 2	5.0 Volt Calibration value for Analog Output 2
103	Full Scale Gas 3	5.0 Volt Calibration value for Analog Output 3
104	Zero Adjust Gas 1	0.5 Volt Calibration value for Analog Output 1
105	Zero Adjust Gas 2	0.5 Volt Calibration value for Analog Output 2
106	Zero Adjust Gas 3	0.5 Volt Calibration value for Analog Output 3
107	Negative 10V Supply	
108	NA	
109	NA	
110	Instrument State	
111	CO Linearisation Factor A	
112	CO Linearisation Factor B	
113	CO Linearisation Factor C	
114	CO Linearisation Factor D	
115	CO Linearisation Factor E	
116	Instrument Units	0= PPM 1=PPB 2=PPT 3=mG/M <sup>3</sup> 4=μG/M <sup>3</sup>

		5=nG/M <sup>3</sup>
117	Background Measure Time	In seconds
118	Sample Fill Time	In seconds
119	Sample Measure Time	In seconds
120	Aux Measure Time	In seconds
121	Aux Sample Fill Time	In seconds
122	Background Fill Time	In seconds
123	Zero Fill Time	In seconds
124	Zero Measure Time	In seconds
125	Span Fill Time	In seconds
126	Span Measure Time	In seconds
127	Span Purge Time	In seconds
128	Background Pause Time	In seconds
129	Background Interleave Factor	In seconds
130	Calibration Pressure 2	
131	AUX Instrument Gain	
132	Background voltage	
133	AUX Background Voltage	
134	O3 Generator Output	PPM
135	O3 Generator On/Off	
136	Calibration Point 1	PPM
137	Calibration Point 2	PPM
138	Calibration Point 3	PPM
139	Calibration Point 4	PPM
140	Calibration Point 5	PPM
141	Desired Pump Flow	SLPM
142	Actual Pump Flow	SLPM
143	Set Lamp Current	%
144	Lamp Current	mA
145	Cycle Time	Minutes
146	CO Cooler Pot	CO Cooler voltage adjustment POT
147	CO Source Pot	CO Source voltage adjustment POT
148	CO MEASURE Test Pot 0	CO MEASURE TEST POT
149	CO REFERENCE Test Pot 1	CO REFERENCE TEST POT
150	O3 REF Average	S10 Background Average
151	PTF Gain 0	Pressure Temperature Flow Compensation Factor for first gas
152	PTF Gain 1	Pressure Temperature Flow Compensation Factor for second gas in dual gas analyzers.
153	Inst. Cell Pressure	Instantaneous cell pressure
154	Manifold Pressure	Valve Manifold Pressure
155	Cell Gas 1 Pressure	Cell Pressure for Gas 1
156	Cell Gas 2 Pressure	Cell Pressure for Gas 2
157	Cell Bgnd Pressure	Cell Pressure when in Background
158	Reserved	
159	Reserved	
160	Reserved	
161	Temperature Units	0 = "°C",

		1 = "°F", 2 = "°K",
162	Pressure Units	0 = "torr", 1 = "psi", 2 = "mbar", 3 = "atm", 4 = "kPa"
163	Averaging Period	0 = " 1 Min", 1 = " 3 Mins", 2 = " 5 Mins", 3 = "10 Mins", 4 = "15 Mins", 5 = "30 Mins", 6 = " 1 Hr", 7 = " 4 Hrs", 8 = " 8 Hrs", 9 = " 12 Hrs", 10 = " 24 Hrs"
164	Filter Type	NO FILTER = 0, KALMAN FILTER = 1, 10 SEC FILTER = 2, 30 SEC FILTER = 3, 60 SEC FILTER = 4, 90 SEC FILTER = 5, 300 SEC FILTER = 6, ADPTIVE FILTER =7
165	NO2 Filter	0 = Disabled, 1 = Enabled
166	Background Interval	0 = "24 Hrs", 1 = "12 Hrs", 2 = "8 Hrs", 3 = "6 Hrs", 4 = "4 Hrs", 5 = "2 Hrs", 6 = "Disable"
167	Service Baud	0 = " 1200 bps", 1 = " 2400 bps ", 2 = " 4800 bps ", 3 = " 9600 bps ", 4 = "14400 bps ", 5 = "19200 bps ", 6 = "38400 bps "
168	Multidrop Baud	0 = " 1200 bps", 1 = " 2400 bps ", 2 = " 4800 bps ", 3 = " 9600 bps ", 4 = "14400 bps ", 5 = "19200 bps ", 6 = "38400 bps "
169	Service Port (COM 1) Protocol	0 = " EC9800", 1 = "Bavarian",

		2 = "Advanced"
170	Multidrop Port (COM 2) Protocol	0 = " EC9800", 1 = "Bavarian", 2 = "Advanced"
171	Gas1 Over Range	The Upper Concentration Range when Over-Ranging is enabled for Analog Output 1
172	Gas2 Over Range	The Upper Concentration Range when Over-Ranging is enabled for Analog Output 2
173	Gas3 Over Range	The Upper Concentration Range when Over-Ranging is enabled for Analog Output 3
174	Gas1 Over Ranging	0 = Over Ranging Disabled 1 = Over Ranging Enabled (Gas1)
175	Gas2 Over Ranging	0 = Over Ranging Disabled 1 = Over Ranging Enabled (Gas2)
176	Gas3 Over Ranging	0 = Over Ranging Disabled 1 = Over Ranging Enabled (Gas3)
177	Heater Set Point	Cell Heater Set Point
178	PMT HV Ctrl POT	PMT High Voltage Controller POT
179	PMT Test LED POT	PMT Test LED intensity controller POT
180	Last Power Failure Time	Time Stamp of the Last power fail (4 byte time stamp)  Bit 31:26 ---- Year (0 – 99) Bit 25:22 ---- Month ( 1 – 12) Bit 21:17 ---- Date (1 – 31) Bit 16:12 ---- Hour (00 – 23) Bit 11:06 ---- Min (00 – 59) Bit 05:00 ---- Sec (00 – 59)
181	Instantaneous Manifold Pressure	Instantaneous Manifold Pressure in S40 analyzers (no filter)
182	Cell Pressure (gas3)	Cell Pressure for Gas 3
183	Gas 4 Concentration	Current value of Gas 4
184	Gas 5 Concentration	Current value of Gas5
185	Gas 4 Average	Average of the readings(for Gas4) of the last n minutes where n is the averaging period
186	NH3 Converter Efficiency	
187	Cell / Lamp M/S Ratio	
188	Mirror Temperature M/S Ratio	
189	Flow Temperature M/S Ratio	
190	Cooler Temperature M/S Ratio	
191	Moly Temperature M/S Ratio	
192	CO Conv Temperature M/S Ratio	
193	Full Scale Current Gas 1	
194	Full Scale Current Gas 2	
195	Full Scale Current Gas 3	
196	Zero Adjust Current Gas 1	
197	Zero Adjust Current Gas 2	
198	Zero Adjust Current Gas 3	

199	External Analog Input 1	
200	External Analog Input 2	
201	External Analog Input 3	
202	Converter Set Point	Converter Set Point Temperature

## Appendix B – EC9800 Protocol

### DCONC

<b>Function</b>	Sends the current instantaneous concentration data to the serial port.
<b>Format</b>	DCONC,{<DEVICE I.D.>}{TERMINATOR}
<b>Device response</b>	{GAS}<SPACE>{STATUS WORD}<CR><LF>

All numbers are in floating point format. The STATUS WORD indicates the instrument status in hex using the following format:

Bit 15	= SYSFAIL (MSB)
Bit 14	= FLOWFAIL
Bit 13	= LAMPFAIL
Bit 12	= CHOPFAIL
Bit 11	= CVFAIL
Bit 10	= COOLERFAIL
Bit 9	= HEATERFAIL
Bit 8	= REFFAIL
Bit 7	= PS-FAIL
Bit 6	= HV-FAIL
Bit 5	= OUT OF SERVICE
Bit 4	= instrument is in zero mode
Bit 3	= instrument is in span mode
Bit 2	= unused
Bit 1	= SET→PPM selected, CLEAR→MG/M3
Bit 0	= reserved (LSB).

### DSPAN

<b>Function</b>	Commands the unit under test to enter the span mode and stay there.
<b>Format</b>	DSPAN,{<DEVICE I.D.>}{TERMINATOR}
<b>Device response</b>	<ACK> if the unit under test is able to perform the command, <NAK> if not.

### DZERO

<b>Function</b>	Commands the unit under test to enter the zero mode and stay there.
<b>Format</b>	DZERO,{<DEVICE I.D.>}{TERMINATOR}
<b>Device response</b>	<ACK> if the unit under test is able to perform the command, <NAK> if not.

### ABORT

<b>Function</b>	Commands the addressed device to abort the current mode and return to the measure mode.
<b>Format</b>	ABORT,{<DEVICE I.D.>}{TERMINATOR}

<b>Device response</b>	<ACK> if the unit under test is able to perform the command, <NAK> if not.
<b>RESET</b>	
<b>Function</b>	Reboots the instrument (software reset).
<b>Format</b>	RESET, {<DEVICE I.D.>}{TERMINATOR}
<b>Device response</b>	<ACK>

## Appendix C – Bavarian Protocol

### Bavarian Network Command Set Format

All Bavarian Network commands follow the command format as specified in this section. The specific Bavarian commands and their function are described in section

Bavarian Network Command Format: <STX><TEXT><ETX><BCC1><BCC2>

Where:

<STX> = ASCII Start Of Transmission = 02 hex  
 <TEXT> = ASCII text maximum length of 120 characters  
 <ETX> = ASCII end of transmission = 03 hex  
 <BCC1> = ASCII representation of block check value MSB  
 <BCC2> = ASCII representation of block check value LSB.

The block check algorithm begins with 00 Hex and exclusive-OR each ASCII character from <STX> to <ETX> inclusive. This block check value is then converted to ASCII format and sent after the <ETX> character.

### Examples

The following is an example of a valid Bavarian data request for an instrument that has an I.D. of 97:

<STX>DA097<ETX>3A

The block check calculation is best shown by the following table:

Character	Hex Value	Binary Block Check
<STX>	02	0000 0010
D	44	0100 0100
A	41	0100 0001
0	30	0011 0000
9	39	0011 1001
7	37	0011 0111
<ETX>	03	0000 0011

The binary value 0011 1010 corresponds to the hex value 3A. This value in ASCII forms the last two characters of the data request message. Please note that the I.D. of 97 is sent as the sequence 097. All I.D. strings must have 3 digits and the user should always pad with ASCII zero characters.

This is an example of a valid command to put the unit in the manual span mode if the instrument has an I.D. of 843:

<STX>ST843 K<ETX>52

The block check operation is best shown with the following table:

Character	Hex Value	Binary Block Check
<STX>	02	0000 0010
S	53	0101 0011
T	54	0101 0100
8	38	0011 1000
4	34	0011 0100
3	33	0011 0011
	20	0010 0000
K	4B	0100 1011
<ETX>	03	0000 0011

The binary block check value is 0101 0010 which is the hex value 52 as shown at the end of the command string.

